

Part V - Features of Composition Languages

50. Configuration with Acyclic Composition Programs

- 1) Configuration management with acyclic comp. programs
- 2) Lazy evaluation of composition programs

Obligatory Reading

- ▶ ISC book Chapter 3, 4

Literature

- ▶ Dami, Laurent. Software Composition. PhD University Geneva 1997. The centennial work of the Lambda-N calculus
- ▶ Mulet, P., Malenfant, J., Cointe, P. Towards a Methodology for Explicit Composition of MetaObjects. OOPSLA 98.
- ▶ Forman, Danforth: MetaClasses in C++. Addison Wesley. 1999. Excellent book on metaclasses and metaclass composition.
- ▶ Oscar Nierstrasz and Theo Dirk Meijler. Requirements for a composition language. In Paolo Ciancarini, Oscar Nierstrasz, and Akinori Yonezawa, editors, Object-Based Models and Languages for Concurrent Systems, LNCS 924, pages 147-161. Springer, 1995.

Component and Composition Language Level

- ▶ Holds for black-box and grey-box composition systems

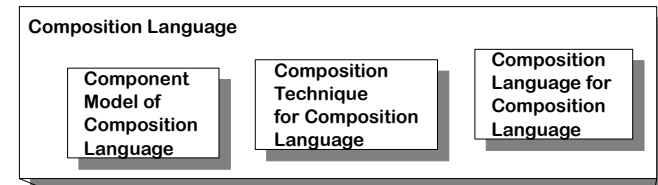

Composition Level

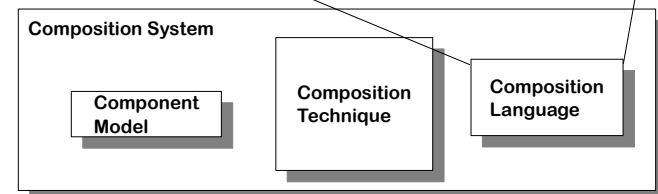

System Builds as Composition Expressions and Programs

- A composition expression or composition program in a composition language describes a system build

Prof. U. Altmann, CBSE



Composition Level

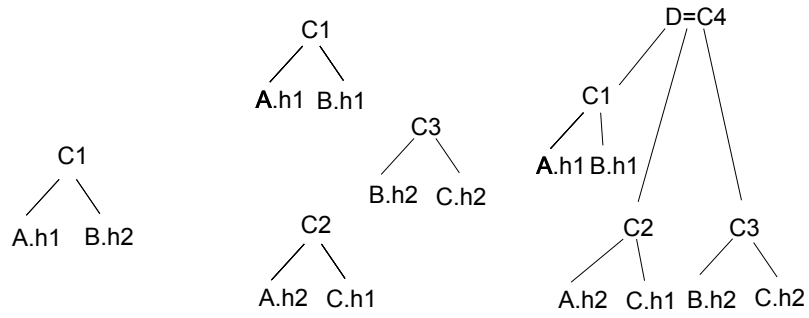

Component Level

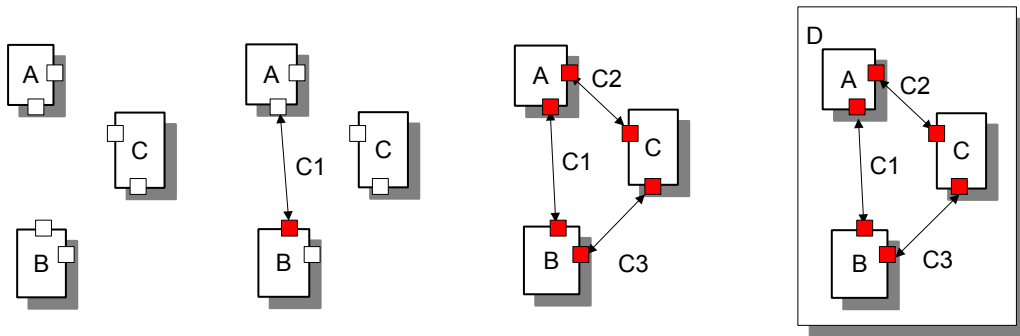

A System Builder Executes a Composition

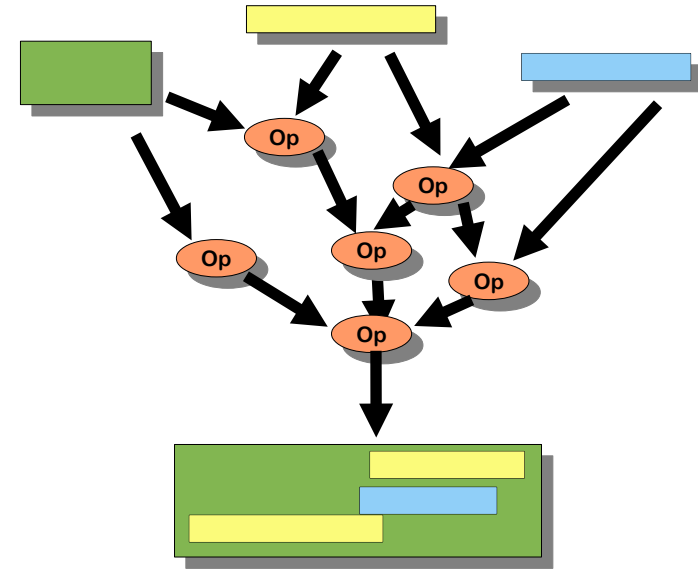

Prof. U. Altmann, CBSE



Composition Level

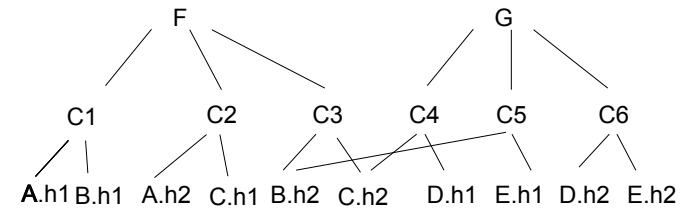

Component Level

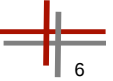
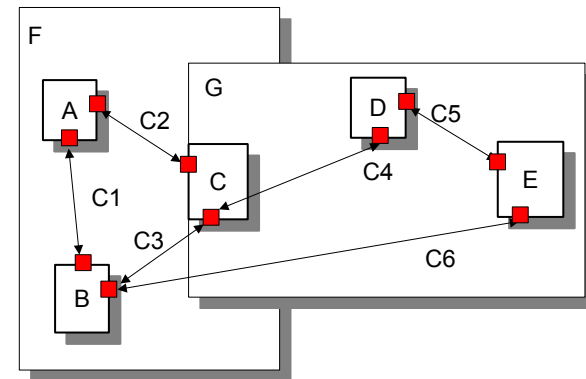

50.1 Configuration Management With Acyclic Composition Programs



Turing-Completeness of Composition Languages

- ▶ If a composition language is *not* turing-complete
 - The architecture of the system is simple
 - Can be analyzed much better:
 - Termination can be proved
- ▶ If a composition language *is* turing-complete
 - The system is more complex
 - Complex architectures, also recursive ones, can be described



Configuration as Control-Flow of Composition Programs

- ▶ Composition programs may contain control-flow statements
- ▶ They are executed *before* the components run
 - They *configure* the components, because they depend on static control-flow conditions
 - Global configuration variables

A configuration of a system relies on an acyclic composition program.



A Configuration Variable

- ▶ This composition program is a configuration because it is acyclic
- ▶ Its variables are **configuration switches**

Configuration switch (configuration variable)

```
// Variant selection for instantiation of generic parameter
public class CompositionProgram {
    public static void main (String[] argv) {
        if (argv[1].equals("tin")) variant1= true; else variant1 = false;
        ClassBox SimpleList = compositionSystem.createClassBox("SimpleList");
        if (variant1) {
            ClassBox bagOfPieces =
                SimpleList.bindGenericType("ElementType", "Tin");
        } else {
            ClassBox bagOfPieces =
                SimpleList.bindGenericType("ElementType", "MetalPlate");
        }
    }
}
```

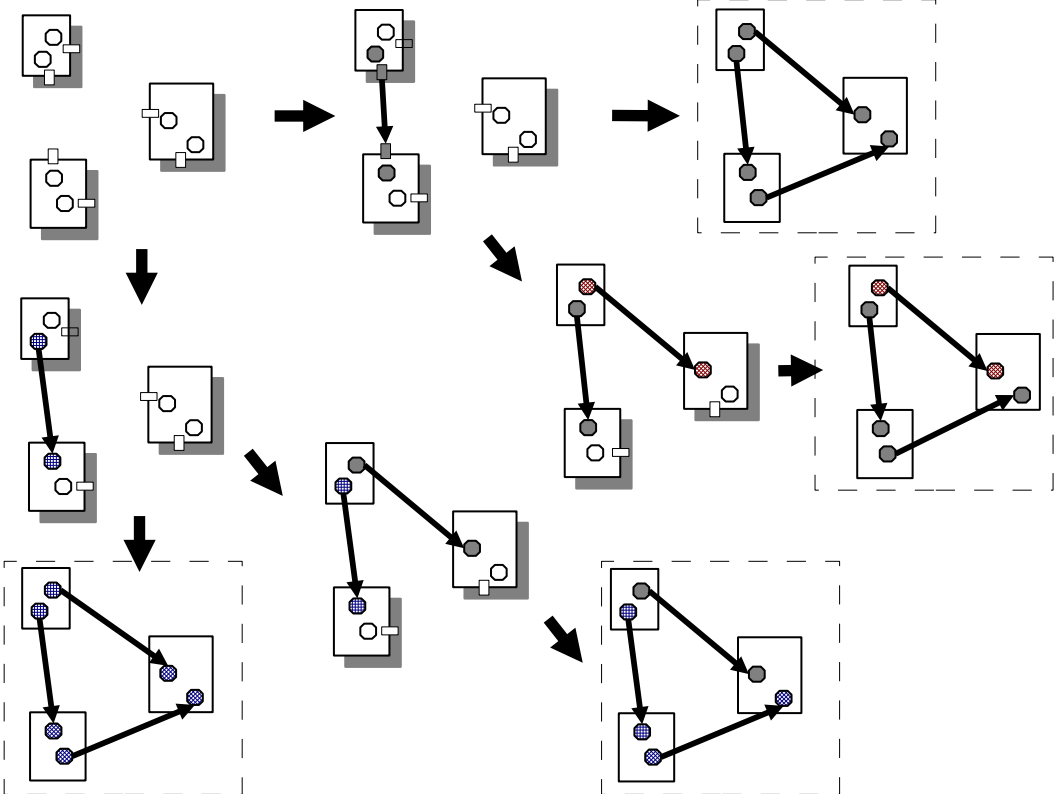

Traditional Configuration with Cpp

- ▶ The C preprocessor is a simple acyclic composition/configuration language
 - with configuration switches for fragment configuration
- ▶ Evaluated statically, before compilation

```
#ifdef ConfigurationVariable
  <fragment variant 1>
#else
  <fragment variant 2>
#endif
```

Prof. U. Altmann, CBSE



50.2 Lazy Evaluation of Composition Programs

Eager and Lazy Builds of Composition Programs

- ▶ As all programs, composition programs can be evaluated with different evaluation strategies
- ▶ Eager: direct execution of all composition operations
- ▶ Lazy: as needed
- ▶ Lazy evaluation is important when
 - Something changes and the system architecture should be recomputed

Prof. U. Altmann, CBSE

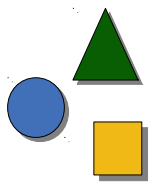

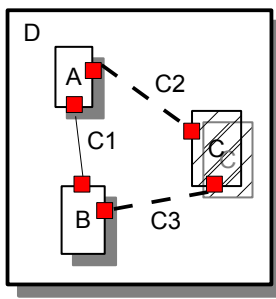

Make as an Example

- ▶ Make is a lazy system builder
- ▶ Composition language is rule-based
 - Rule dependencies are lazily recomputed
 - Composition expressions are applications of UNIX tools (compiler, linker, generator, preprocessor)

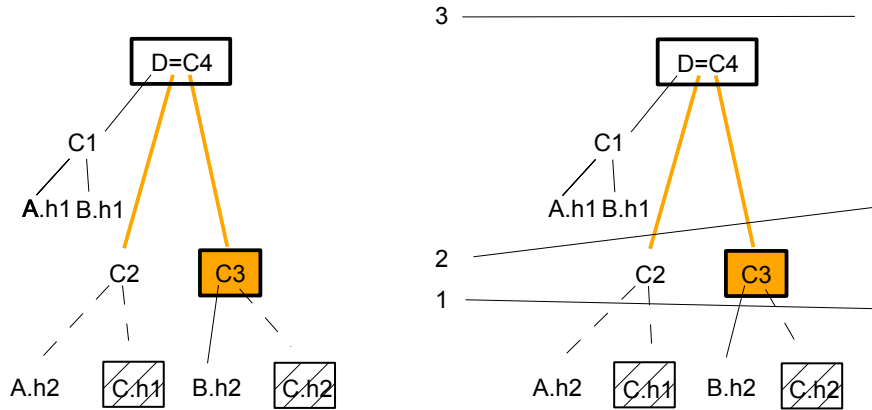

Configuration of Packages with Embedded Composition Programs

- ▶ Composition classes itself can be hooks of packages
- ▶ Then, in system configuration, they can be re-bound (stage 1)
 - This is metacomposition, production of composition programs
- ▶ When the configured composition classes are executed (stage 2)
 - They configure the system differently

Package with Composition Class Hooks

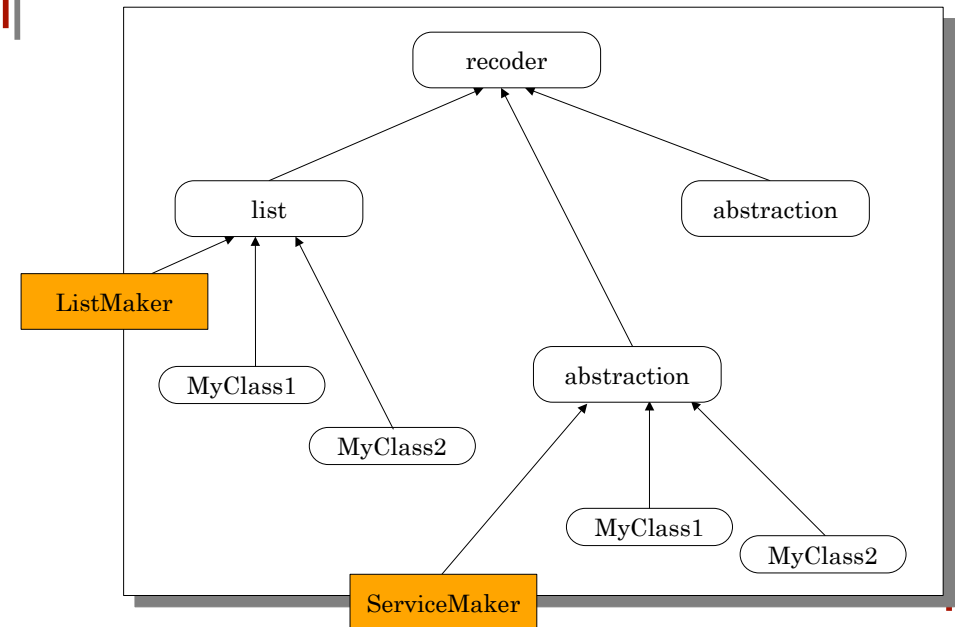

Stage 1: Metacomposition: Binding Composition Programs in Different Variants

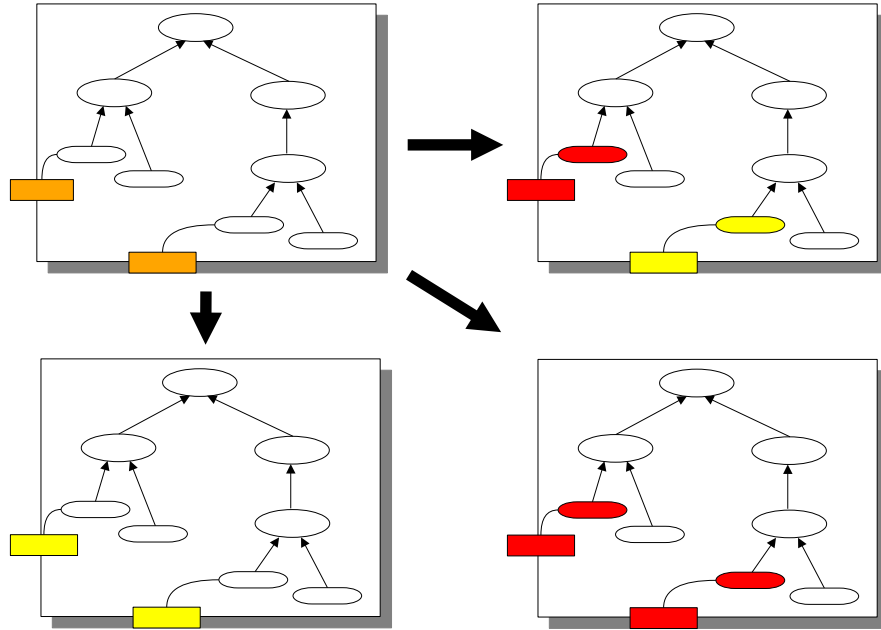

Stage 2: Execution of Composition Programs

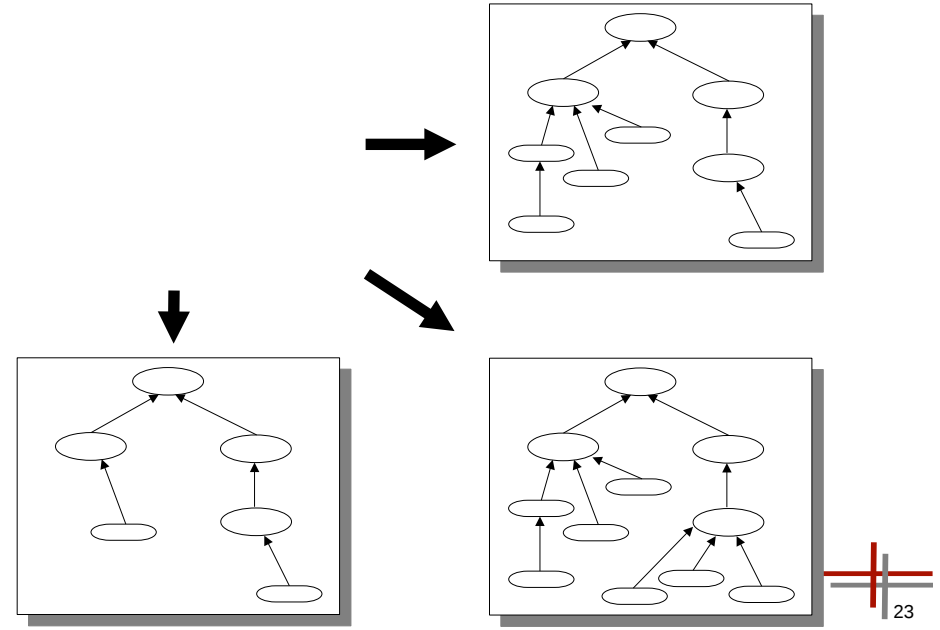

The End