

## 12. Frameworks and Patterns - Framework Extension Patterns



Prof. Dr. U. Aßmann  
Software Engineering Group  
Faculty of Informatics  
Dresden University of  
Technology  
Version 11-0.3, 12/10/11

- 1) Extension Object Pattern
- 2) Large Layered Frameworks
- 3) Role Object Pattern
- 4) GenVoca Pattern
- 5) Mixin Layer Pattern
- 6) Concerns for Layered Frameworks

Design Patterns and Frameworks, © Prof. Uwe Aßmann

1

## Literature (To Be Read)

- ▶ E. Gamma. The Extension Objects Pattern. Conf. On Pattern Languages of Programming (PLOP) 97, ACM.  
<http://portal.acm.org/citation.cfm?id=273448.273455#>
- ▶ Y. Smaragdakis and D. Batory. Mixin layers: an object-oriented implementation technique for refinements and collaboration-based designs. ACM Transactions on Software Engineering and Methodology, 11(2):215–255, 2002.
- ▶ D. Bäumer, D. Riehle, W. Silberski, M. Wulf. Role Object. Conf. On Pattern Languages of Programming (PLOP) 97.  
<http://citeseer.ist.pst.edu/baumer97role.html>
- ▶ D. Riehle, T. Gross. Role Model Based Framework Design and Integration. Proc. 1998 Conf. On Object-oriented Programming Systems, Languages, and Applications (OOPSLA 98) ACM Press, 1998.  
<http://citeseer.ist.pst.edu/riehle98role.html>
- ▶ D. Bäumer, G. Gryczan, C. Lilienthal, D. Riehle, H. Züllighoven. Framework Development for Large Systems. Communications of the ACM 40(10), Oct. 1997. <http://citeseer.ist.pst.edu/bumer97framework.html>

Prof. Uwe Aßmann, Design Patterns and Frameworks



2

## Further Literature

- ▶ D. Bäumer. Softwarearchitekturen für die rahmenwerk-basierte Konstruktion grosser Anwendungssysteme. PhD thesis, 1997, Universität Hamburg.
- ▶ JWAM sites
  - <http://www.c1-wps.de/forschung-und-lehre/fachpublikationen/>
  - [www.jwam.de](http://www.jwam.de)
  - <http://sourceforge.net/projects/jwamtoolconstr/>
- ▶ U. Aßmann. Composing Frameworks and Components for Families of Semantic Web Applications. Lecture Notes In Computer Science, vol. 2901, Nov. 2003.
- ▶ U. Aßmann, J. Johannes, J. Henriksson, and I. Savga. Composition of rule sets and ontologies. In F. Bry, editor, Reasoning Web, Second Int. Summer School 2006, number 4126 in LNCS, pages 68-92, Sept 2006. Springer.
- ▶ Y. Smaragdakis, D. Batory. Mixin Layers: An object-oriented implementation for refinements and collaboration-based designs.
- ▶ Y. Smaragdakis, D. Batory. Implementing layered designs with mixin layers. In Lecture Notes in Computer Science (LNCS) 1998, Springer-Verlag.

Prof. Uwe Aßmann, Design Patterns and Frameworks



3

## Goal

- ▶ Studying extensible framework hook patterns
  - Understand patterns Extensions Object, Role Object, and Genvoca
  - See how layered frameworks can be implemented by Role Object and Genvoca
- ▶ Understand these patterns as extension points of frameworks, i.e., framework hook patterns

Prof. Uwe Aßmann, Design Patterns and Frameworks



4

# Frameworks Must Be Extensible

- ▶ Frameworks must evolve, be adapted
- ▶ Idea: instead of variability hooks, use extensibility hooks
  - based on basic extensibility patterns
- ▶ Presented in this lecture:
  - Gamma's Extension Object Pattern (EOP)
  - Layered frameworks
    - Riehle/Züllighoven's RoleObject pattern (ROP)
    - Batory's mixin layer pattern (GenVoca pattern)



# 12.1 The ExtensionObjects Pattern (EOP)



# Structure of ExtensionObjects

- ▶ Whenever a complex object has non-mandatory parts that can be added, if necessary
- ▶ *Extension* is the base class of all extensions
- ▶ *AbstractExtension* defines an interface for a concrete hierarchy of extension objects
- ▶ Extensions can be added, retrieved, and removed by clients

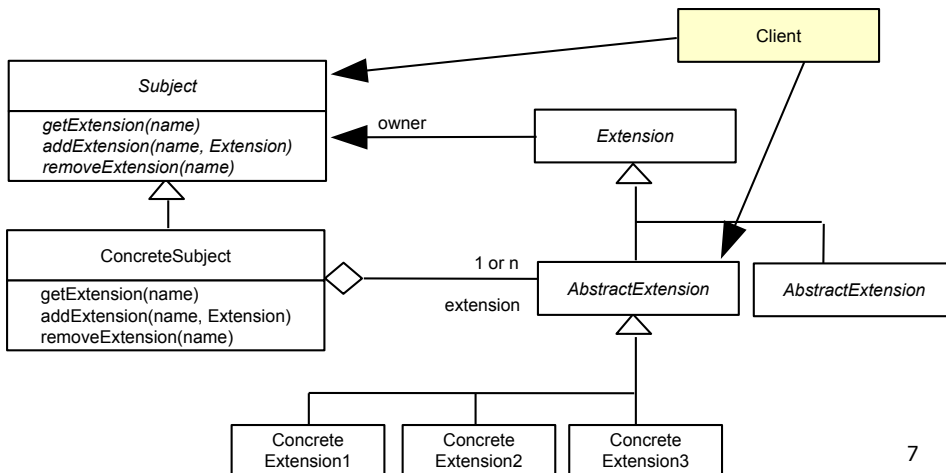

# Example: Spellcheckers in Document Models

- ▶ E.g., OpenDoc or OLE documents

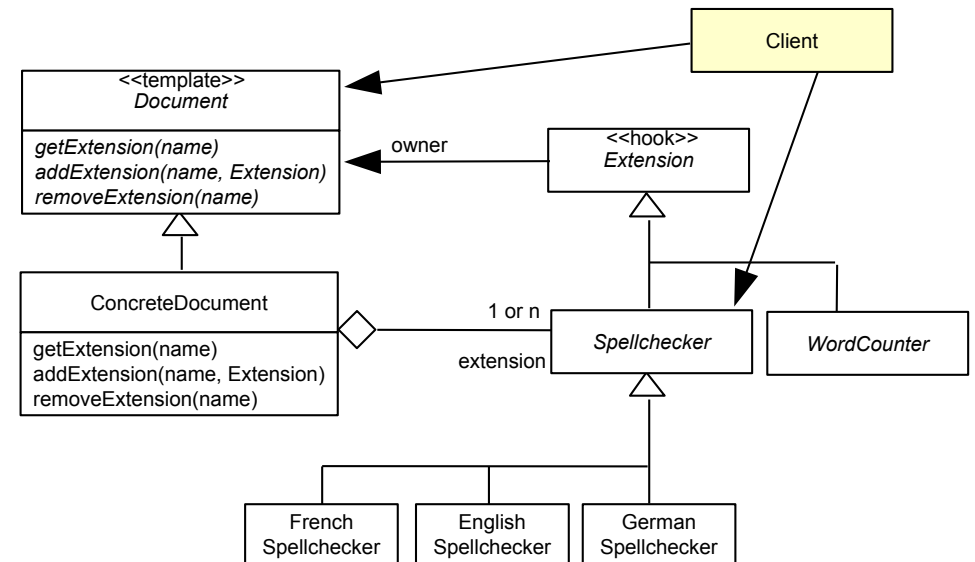

# Discussion of EOP

- ▶ If there is 1 extension object, naming is not necessary
- ▶ If there are n extension objects, a dictionary (map) has to map names to extension objects
- ▶ Advantages
  - Complex objects can be split into simpler parts
  - Extensions can model (optional) roles of objects
  - Extensions can be added dynamically and unforeseen
- ▶ Disadvantage
  - Clients have to manage extension objects themselves, and hence, are more complex
  - Extension objects suffer from the *object schizophrenia* problem: the logical *this* of an extension object is the subject, but the physical *this* is the extension object
- ▶ Relations to Other Patterns
  - If many objects of an application have the same roles that are realized by extension objects, ExtensionObjects can be generalized to the Role Object Pattern

# ExtensionObjects at Framework Borders

- ▶ Since with EOP, clients have to manage extensions themselves, the use of the template object in the framework does not help to use the hook objects

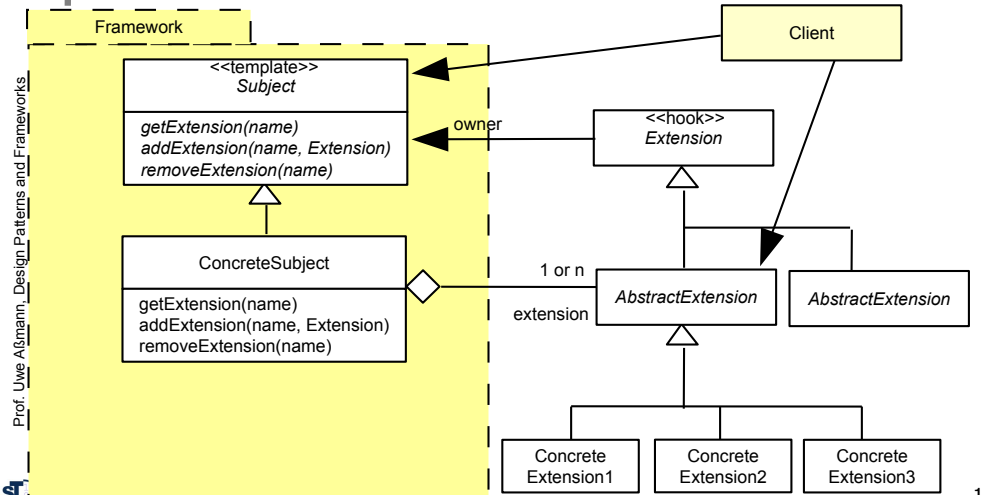

# EOP as Framework Hook Pattern

- ▶ Since the hook object is not mandatory, also 1-H=T is a real extensibility pattern for frameworks

**1-H=T**

T has 1 H part  
T owns H

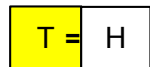
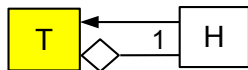

**n-H=T**

T has n H parts  
T owns H parts

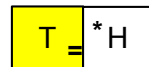
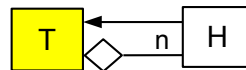

# Optional Tools for Documents in an Office Framework

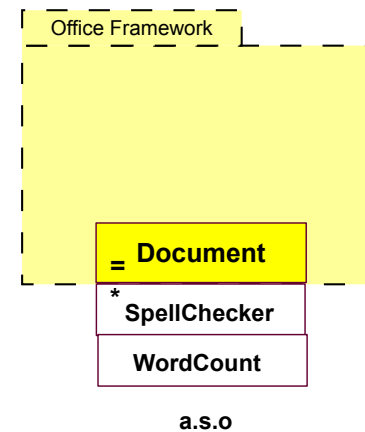



## 12.2 Extensibility of Frameworks with Layers

... with Layered Role Object Frameworks



## Case Study GEBOS

- ▶ GEBOS is a banking application for RWG banking group with 450 banks, south of Germany
  - Banking applications, with services: tellers, loans, stocks, investment, self-service
  - 2500 C++ classes, arranged in frameworks, Arranged in layers
- ▶ Concepts of the bank application domain
  - Banks organize themselves in **business sections** (tellers, loans, etc.)
    - Department of specialists that have a certain expertise (loans, teller, investment)
  - **Workplace contexts**
    - Service centers offer customers an all-in-one service
    - Services of the business sections
    - Every workplace needs different application systems
  - **Business domain**
    - Business objects such as bill, order, account



## Application Framework Layers

- ▶ Gebos demonstrates that it is advantageous to structure an application framework into layers
  - Application layers, Business Section layers, Business domain layers
  - Desktop Layer, Technical kernel layer

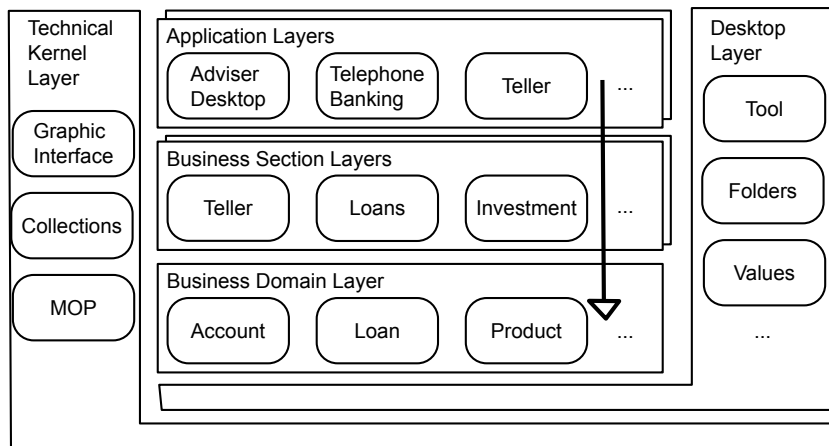

## Layers

- ▶ **Technical Kernel Layer**
  - Service layer, independent of other layers
  - Domain independent, application independent
  - Is a framework itself
    - Collections
    - Middleware
    - Wrappers
    - Garbage collection, late creation, factories, trace support
  - Is a blackbox framework
- ▶ **Desktop Layer**
  - Support for interactive workplaces
  - Contains a tool construction framework (for the Tools&Materials approach)
  - MVC framework, Folder framework, Value framework for business and domain values
    - AccountNumber, clientNumber, Money etc
  - Look and feel, reusable for office domains with GUI applications



# Layers

- ▶ **Business Domain Layer** contains the business core concepts: Account, customer, product, value types
  - Shares knowledge for all business sections
  - Think about how to divide the knowledge between business domain layer and business section layers
- ▶ **Business Section Layers**
  - Subclassing business domain and desktop layers, “inherits” knowledge from both
  - Business section concepts: Borrower, investor, guarantor, loan, loan account, tools. Organizational entities and notions
  - Distinguish from business domain
- ▶ **Application Layers**
  - Application concepts
  - Separate from Business Sections, because workplaces need different functionality from different business sections
  - Uses (and inherits) from all other layers

17

# Goals in Framework Design of GEBOS

- ▶ Minimize coupling between frameworks and application systems
  - Frameworks should never be touched when developing an application system
- ▶ Model different facets of business sections, products, and business domain concepts
  - Use role-object design pattern
- ▶ Minimize coupling between the layers
  - Separate concepts from implementation
  - Move implementation to lower layers
- ▶ Achieved with the RoleObject pattern

18

## 12.3 The RoleObject Pattern

## Framework Extensibility with Riehles Role-Object Layers

- ▶ The Role-Object Pattern (ROP) is both a variability and extensibility pattern
  - Realizes the “dispatch on all layers” for application frameworks
  - Can easily be extended with new layers
- ▶ Extension of a core layer (a blackbox framework of core objects) with layers of delegates (role objects)
  - A **conceptual object (complex object, subject)** of the application is split over all layers
  - **Core** and **role** objects conceptually belong together to the **conceptual** object, but distribute over the layers
  - Role objects are *views* on the conceptual object

20

# Riehle/Züllighovens Role Object Pattern (ROP)

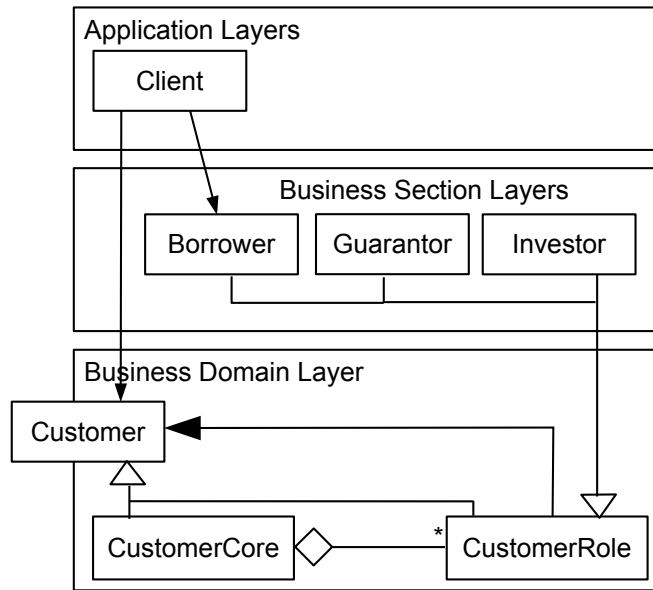

21

# Role Object Pattern with Inheritance Drawn Upwards

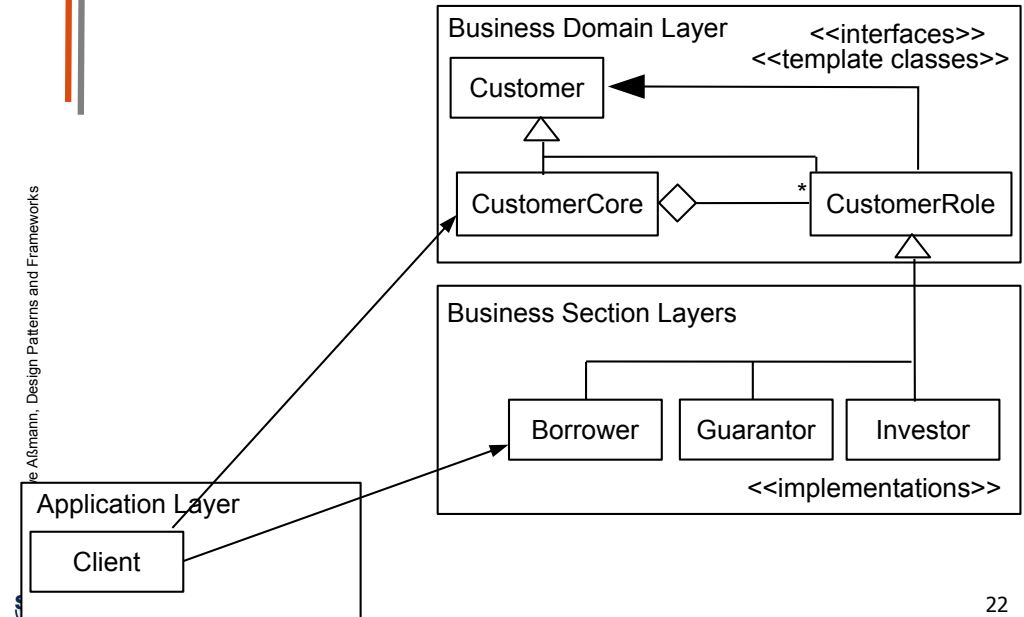

22

# Runtime Behavior

- ▶ At runtime, RoleObjects pass service requests (queries) on to the core
- ▶ The core knows all RoleObjects, and distributes requests (Mediator)
  - The core manages RoleObjects in a *map* that can be dynamically extended

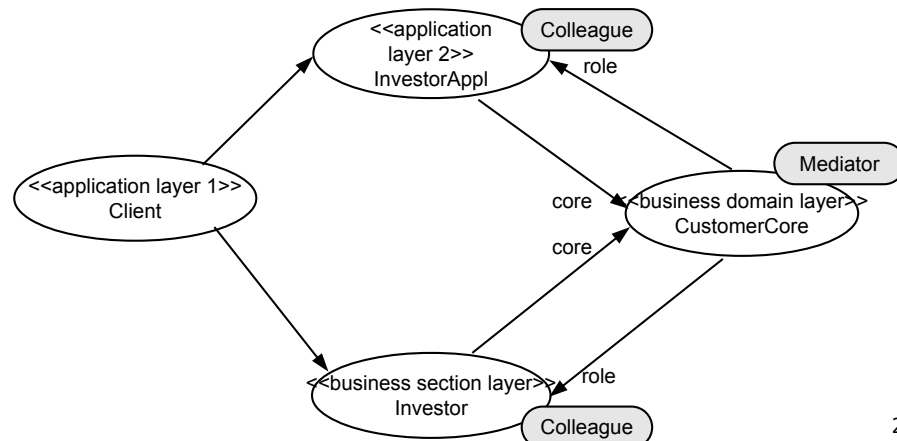

23

# Riehle/Züllighovens Role Object Pattern Abstracted

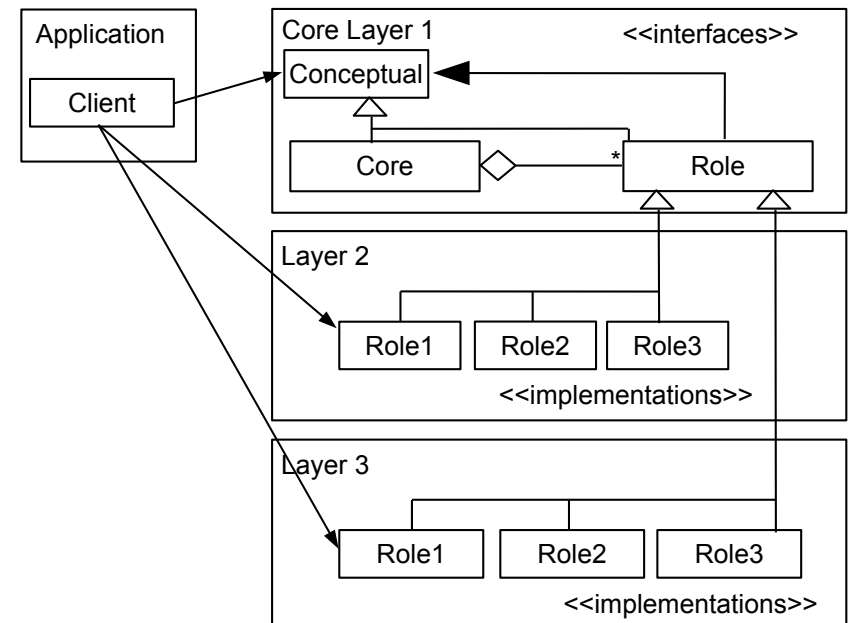

24

# Riehle/Züllighovens Role Object Pattern Variant 2

- ▶ Variant 2 has no Decorator; roles only know cores

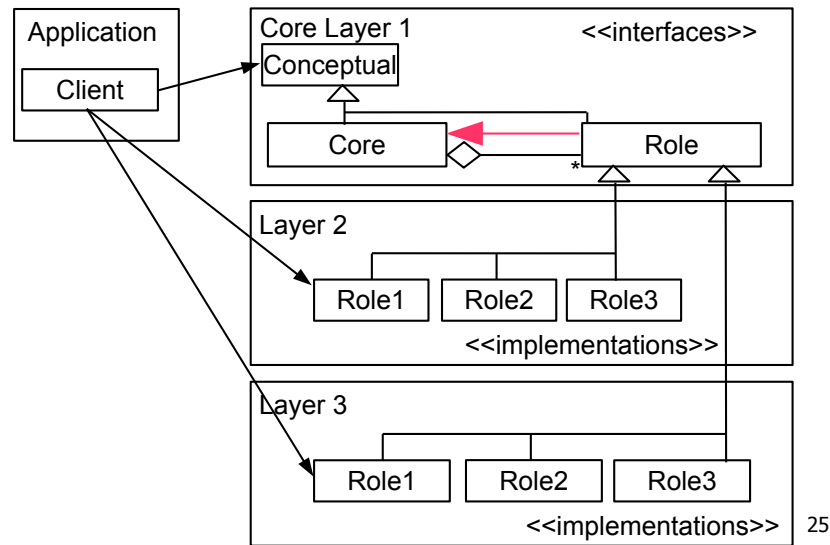

25

# Structure of Core Layer

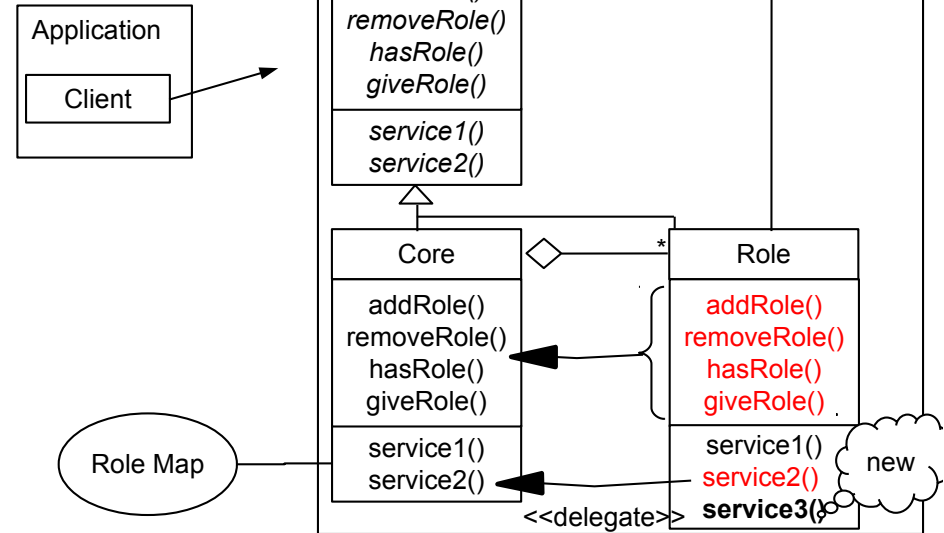

26

# Run-time Behavior of ROP

- ▶ Different Role Objects may belong to the same role type (same ability)
- ▶ Over time, the role object for a role type may change, due to polymorphic behavior of the role
  - This expresses states of the role type in the application
    - E.g., Borrower --> UnsafeBorrower --> TrustedBorrower
- ▶ Roles are created on-demand
  - In the beginning, the Subject is *slim*, i.e., carries few roles.
  - At service requests, the core creates roles and enters them in the role map

27

# Core Layer with Traded Call

- ▶ To add services dynamically (beyond the service interfaces in the conceptual object), add a *trader*
  - A method that interprets a service request based on a service description

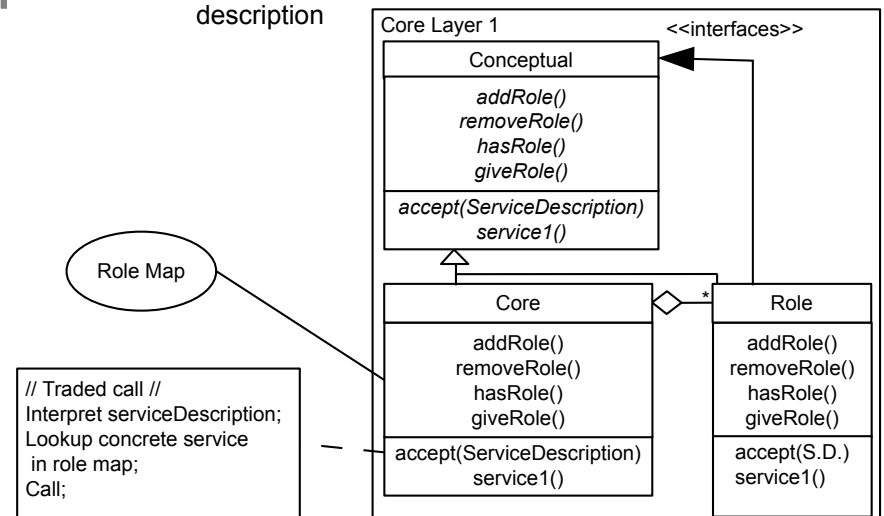

28

# RoleObject and Other Patterns

- ▶ Role object pattern is not only a Decorator
  - It is based on 1-H<=T, i.e., 1-ObjectRecursion
    - All role objects inherit from the abstractum
  - Remember, 1-ObjectRecursion based patterns lend themselves to extension
  - And 1-H<=T framework hook patterns provide extensible frameworks
  - 1:n relationship between core and role objects
  - Role objects decorate the core object, and pass requests on to it



# Role Object Pattern Vs Inheritance (White-Box Framework Layers)

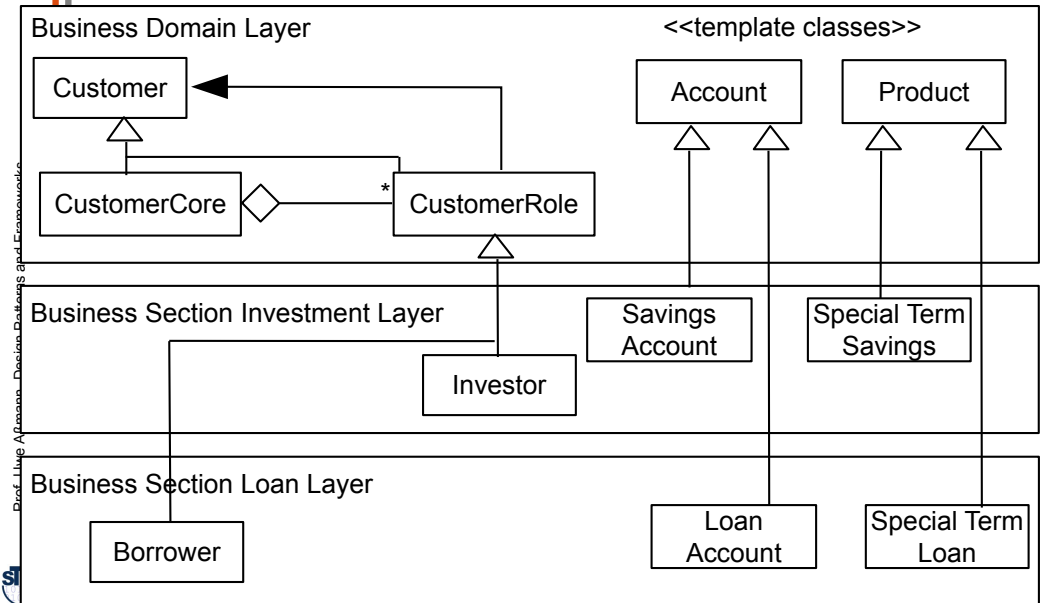

# Role Object Pattern Vs Inheritance (White-Box Framework Layers)

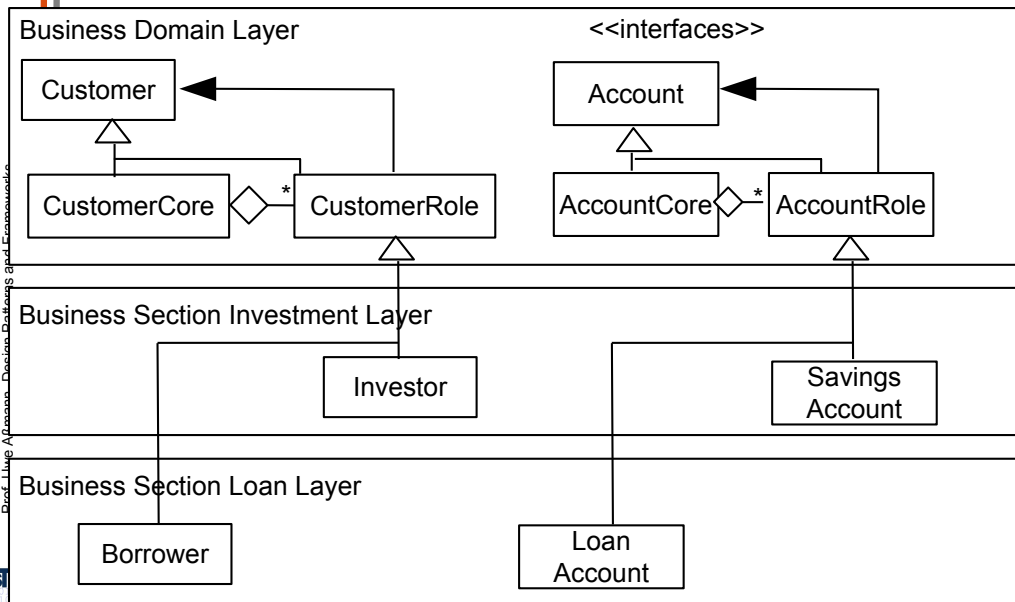

# Comparison of Role Objects with Inheritance

- ▶ Simple inheritance has one instance of a subclass at a time
  - Subclass can change over time (polymorphism)
- ▶ The role object has many of them at the same time
  - All role objects can change (role polymorphism)
- ▶ Only changes in the base layers (technical, presentation, business) affect other layers
  - Changes in the business section layers do not affect the business domain layers
- ▶ The relation of core and role objects is a special form of part-of (combined with inheritance)





# Role Object Pattern with Template and Hook Roles

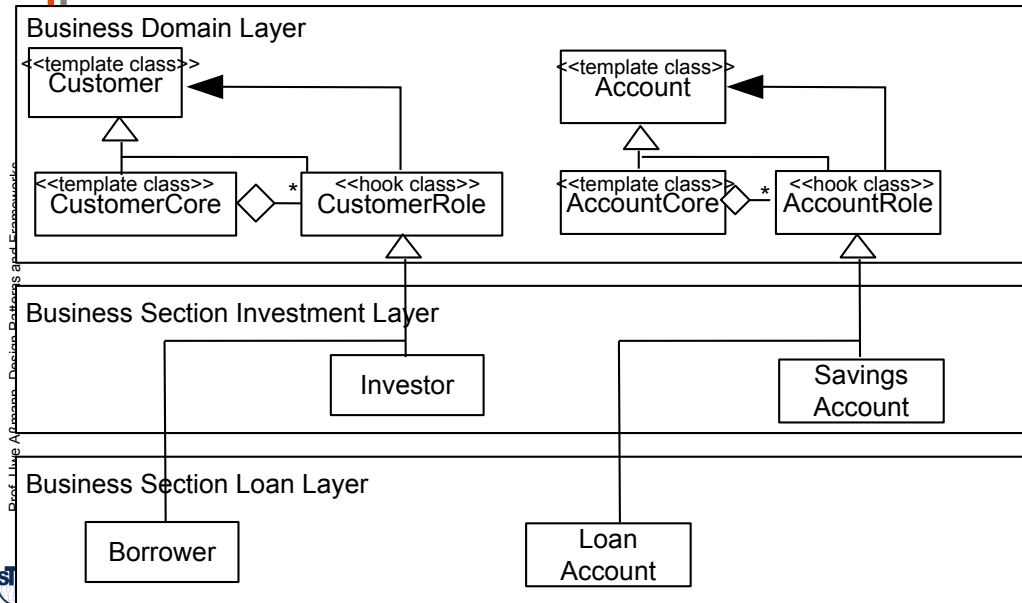

# Riehle/Züllighovens Layer Pattern As Framework Hook Pattern

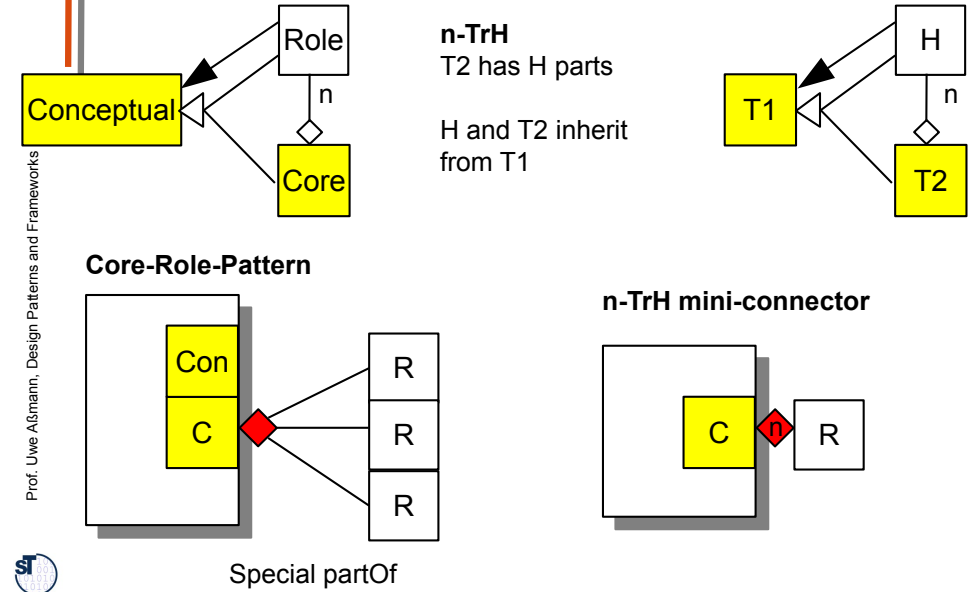

# RoleObject Ensures Extensibility

- ▶ The RoleObject pattern lends itself not only to variability, but also to static and dynamic extensibility
  - If a framework hook is a role object pattern, the hook can be extended in unforeseen ways **without** changing the framework!
  - New layers of the application or the framework can be added at design time or runtime
- ▶ Powerful extension concept
  - Whenever you have to design something complex which should be extensible in unforeseen ways, consider Role Object

# Riehle/Züllighovens Layered Role Object Framework

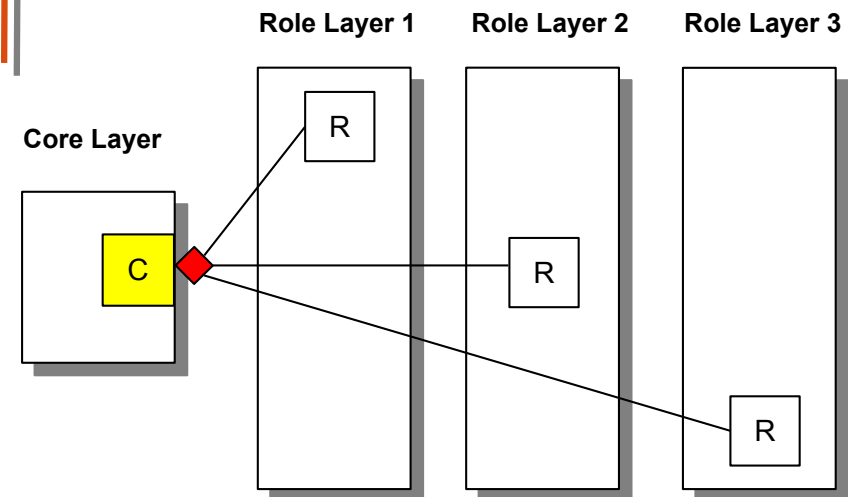

# Extension in Layered Role Object Frameworks

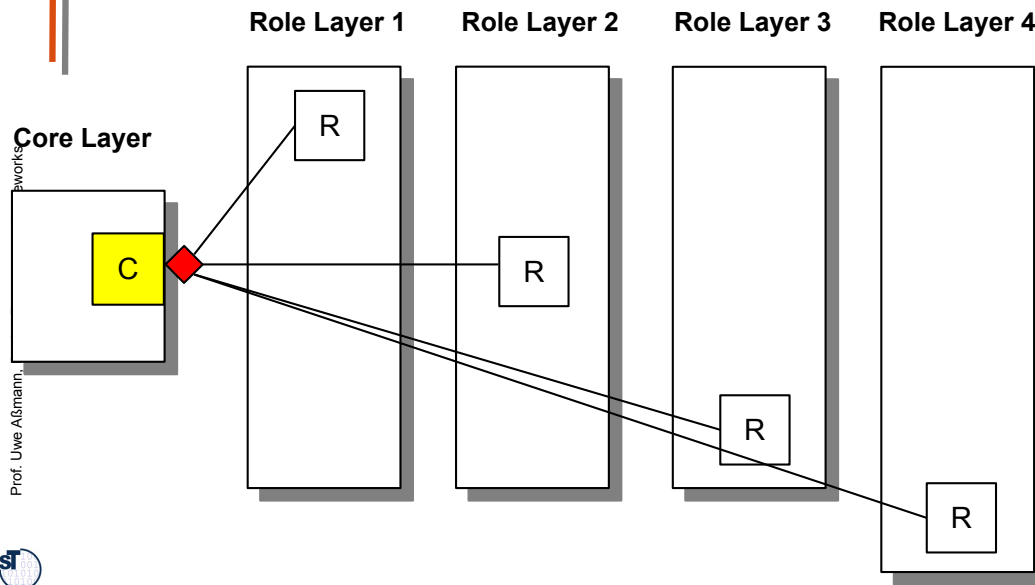

Prof. Uwe Alsmann, Design Patterns and Frameworks

# RoleObject Can Implement Dimensions That Are Not Independent

- ▶ The role objects implement dimensions
  - Core object implements primary dimension
  - Role object secondary dimension
- ▶ Role objects realize *one conceptual object*, instead of a role model crosscutting several conceptual objects
  - Facets are independent dimensions of a conceptual objects
  - Every dimension can be varied independently
- ▶ Comparison to the standard implementation of facets by Multi-Bridge (see Chapter "Simple Extensibility")
  - Multi-Bridge has no inheritance between ConceptualObject, Core and Role
  - Multi-Bridge suffers from object schizophrenia, ROP can implement "this()" on itself without object schizophrenia
  - Calls to the role are not dispatched to the LogicalObject
  - Bridges must not inherit from each other, RoleObjects can

Prof. Uwe Alsmann, Design Patterns and Frameworks

# Benefit of Layered Role Objects Frameworks

- ▶ Implements conceptual objects with layered dependent dimensions
  - Not only independent dimensions
- ▶ Together with layering,
  - Easily extensible
  - Enormous variability
  - Simple structure for extensible product line architecture results
- ▶ For instance: **Layered Frameworks for Business Software**
  - Dispatch on all layers is necessary
    - Implementation without multimethods (in standard languages) *very hard*. Only CLOS, Cecil, and MultiJava are good here
  - That is one reason why business frameworks are so hard
    - SanFrancisco business framework of IBM didn't make it though a dynamic extensibility pattern
    - That's also why these applications are so expensive

Prof. Uwe Alsmann, Design Patterns and Frameworks

# The JWAM Framework

- ▶ Java WAM (Werkzeug Automat Material) is a layered framework for the Tools&Material pattern language [www.jwam.de](http://www.jwam.de)  
<http://sourceforge.net/projects/jwamtoolconstr/>
- ▶ The JWAM site has a lot of interesting papers, e.g., the PhD thesis of Bäumer

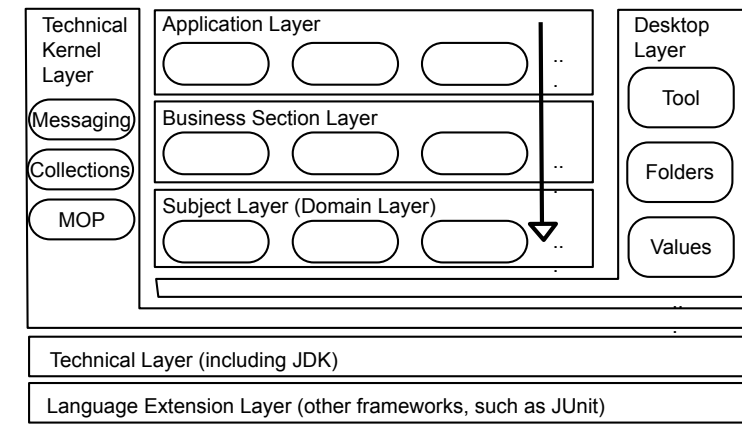

Prof. Uwe Alsmann, Design Patterns and Frameworks

# JWAM has a Kernel

- ▶ 100 classes and interfaces
- ▶ Simple applications can be built with the kernel only
- ▶ Extensions can be added, extension components:
  - Equipment components
    - Ready to use packages such as desktop, registry, form-service
  - Integration components
    - Database connection...



# 12.4 The GenVoca Pattern, Mixin Layers, and Layered Mixin Frameworks



# The Mixin Concept

- ▶ A Mixin is a partial class, for an extension of another class
- ▶ Some languages have mixins (Scala, C#, Eiffel)
- ▶ Otherwise, mixins can be expressed as class fragments that can be parameterized with a superclass
- ▶ Mixins can implement (static) roles and facets

```
template <class S>
class EmployeeMixin extends S {
// class extension..
Salary salary;
Employer emp;
}
```

```
EmployeeMixin<Person> employeeOfPerson;
EmployeeMixin<German> employeeOfGerman;
EmployeeMixin<Club> employeeOfClub;
```

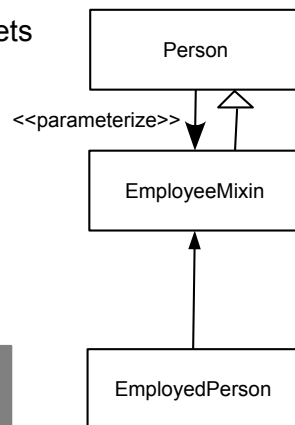

# The GenVoca Pattern

- ▶ If several mixin parameterizations are nested, the GenVoca pattern results [Batory]

```
template <class S> class EmployeeMixin extends S {
Salary salary;
Employer emp;
}
template <class S> class ParentMixin extends S {
Child child;
Money kindergeld;
}
template <class S> class HobbyMixin extends S {
Hobby hobby;
}
// Persons composed with GenVoca pattern
HobbyMixin<ParentMixin<EmployeeMixin<Person>>> assmann;
EmployeeMixin<ParentMixin<HobbyMixin<Person>>> assmann2;
// Have assmann and assmann2 the same type?
```

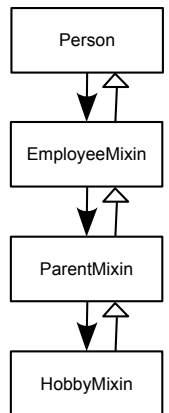

# GenVoca Variations

- When different variants exist for a “abstraction layer”, parameterizations express configurations of a product line

```
// Variants
Person: Man, Woman
ParentMixin: FatherMixin, MotherMixin
EmployeeMixin: TimedEmployee, PermanentEmployee
HobbyMixin: PigeonFriend, Sportsman, GolfPlayer

// Compositions
GolfPlayer<TimedEmployee<Father<Man>>> assmann;
PigeonFriend<PermanentEmployee<Father<Man>>> miller;
GolfPlayer<PermanentEmployee<Mother<Woman>>> brown;
```



# Variations on Different Abstraction Layers form Product Variants

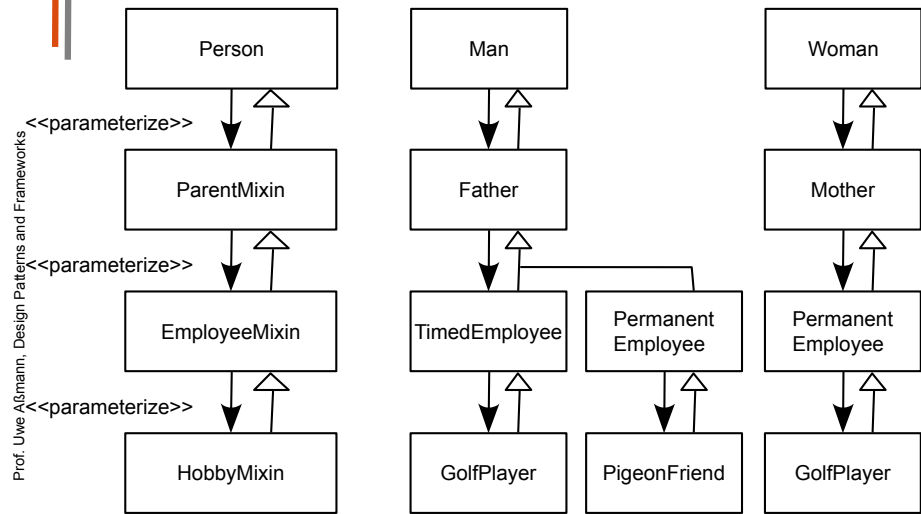

# Variations on Different Role Layers

- Abstraction layers correspond to *role layers* of complex objects
- Roles *collaborate*, but are not implemented by role objects, but by mixins

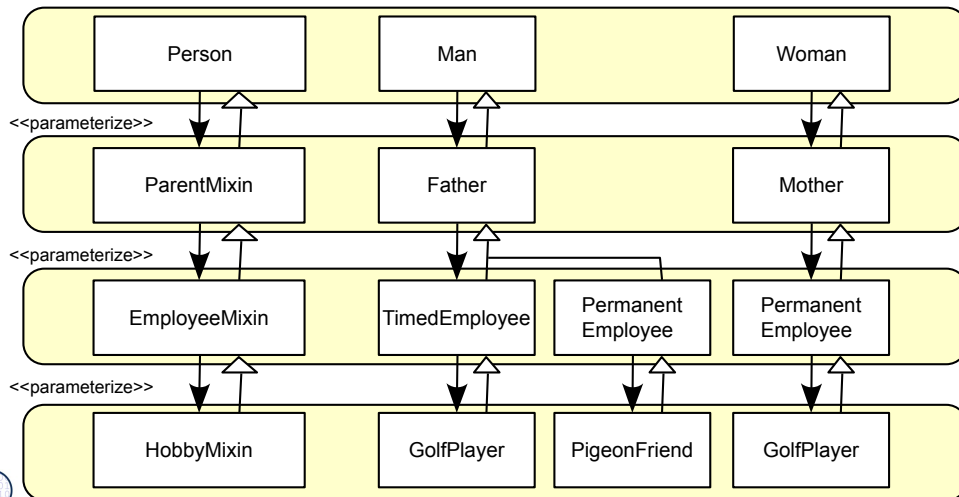

# Discussion

- A *mixin layer* groups all mixins of a role abstraction layer
- Mixins play in the GenVoca pattern the same role as role objects in the role object pattern and layered role frameworks
  - However, all role objects are *embedded* into one physical object
  - There is a physical identity for the entire logical object
  - No object schizophrenia to be avoided
  - GenVoca applications are more efficient, since they merge all roles together into one physical object (see the Alßmann's law on role merging)
- Similarly to layered role object frameworks, layered GenVoca frameworks can model big product lines
  - Every abstraction layer (mixin layer) expresses variability
  - New mixin layers model extensibility



## 12.5 The Mixin Layer Pattern

- While the GenVoca pattern deals with single stacking of parameterizations, the MixinLayer pattern groups all roles of an abstraction layer together and composes entire layers
- MixinLayer treats all logical objects of an application

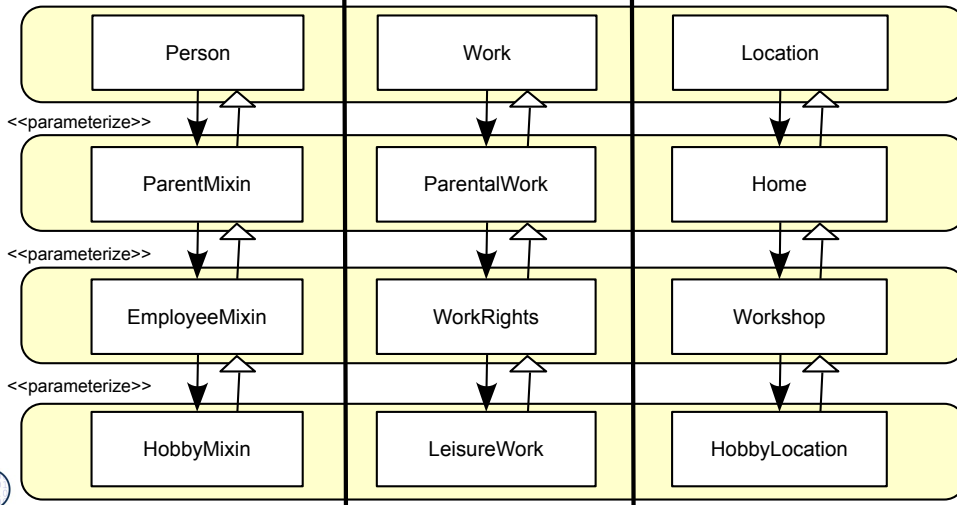

## Mixin Layers as Compositional Unit

- A mixin layer gets a name and can be exchanged consistently for a variant, changing the behavior of the entire layer

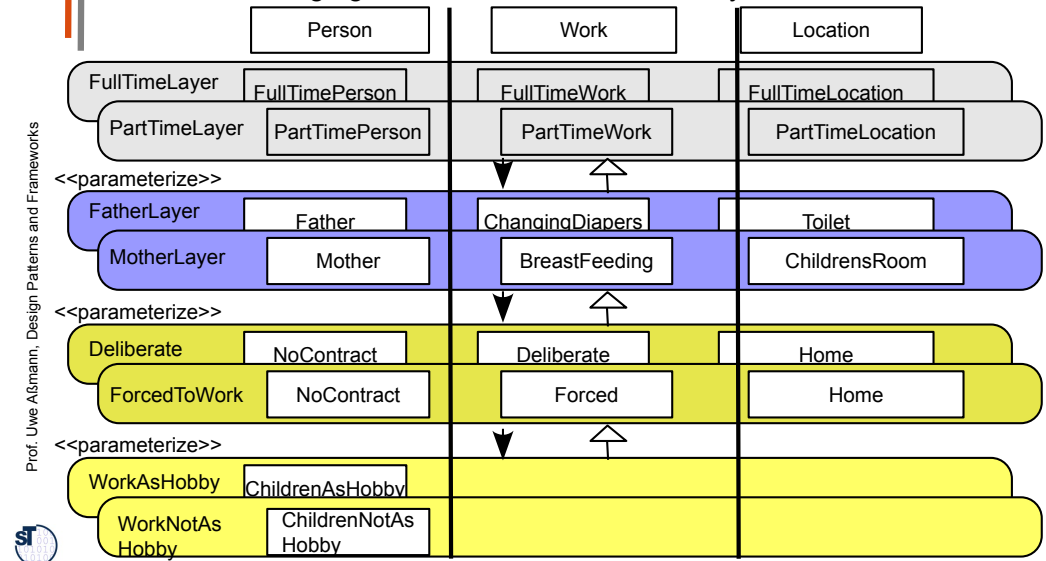

## Composition of Mixin Layers

- Mixin layers are composed similarly to single GenVoca mixins
  - Meaning: All role classes are consistently exchanged with their layer

```
CoreLayer: FullTime, PartTime
ParentLayer: FatherLayer, MotherLayer
EmployeeLayer: Deliberate, ...
HobbyLayer: WorkAsHobby, Slave....

// This is now mixin layer composition!
WorkAsHobby<Deliberate<FatherLayer<FullTime>>>> assmann;
```

## Implementation of Mixin Layers with GenVoca Pattern and Inner Classes

- The role classes of upper layers form super classes of the layer class
- The following pattern allows for separate parameterization of all role mixins, *not* the layer as a whole

```
class Layer <class Super, class RoleSuper1, .., class RoleSupern>
  extends Super {
    class Role1 extends RoleSuper1 { .. }
    ..
    class Rolen extends RoleSupern { .. }

    .. additional classes..
  }
```

# Implementation of Mixin Layers with Designated Inner Classes

- ▶ If the target language permits to have inner classes that can be designated by an expression, mixin layers can be inherited as a whole
- ▶ The super mixin layer can be selected by one single expression  $L < L1 >$

```
class Layer <class Super>
// The class Super has n inner role classes RoleSuper1, ...,
// RoleSupern
extends Super {
  class Role1 extends Super.RoleSuper1 { .. }
  ..
  class Rolen extends Super.RoleSupern { .. }
  .. additional classes..
}
```

# Layered Mixin Frameworks vs Layered Role Object Frameworks

- ▶ Every mixin layer corresponds to a role layer
- ▶ Mixin layers form *frameworks* that can be extended by mixin layer composition towards applications
- ▶ Same variability effects for big product lines

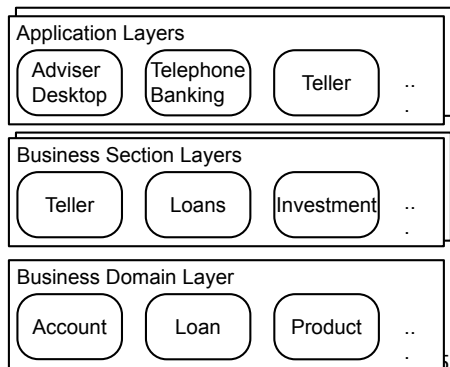
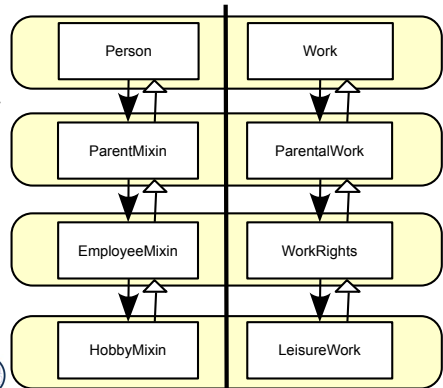

# Example: A Graph Framework

- ▶ Graph applications can be structured into mixin layers
- ▶  $\text{ConnectedOnDFTUndirected} = \text{CRL1} < \text{CL1} < \text{VN1} < \text{TL1} < \text{RL1} > > > >$
- ▶  $\text{ConnectedOnBFTRevDirected} = \text{CRL1} < \text{CL1} < \text{VN2} < \text{TL2} < \text{RL2} > > > >$

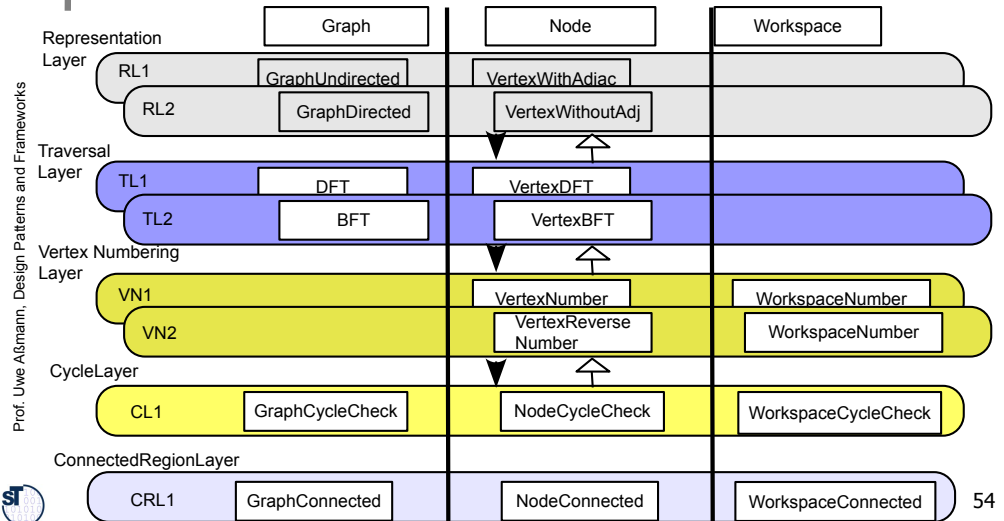

# Layered Mixin Frameworks vs Layered Role Object Frameworks

- ▶ Unfortunately, the direction of generality is usually drawn in the opposite way in mixin layer frameworks and role object frameworks
- ▶ If we agree to put the “most general abstraction layer” downmost, the dependencies go into the same direction
- ▶ Features on the upper layers *depend* on the lower layers

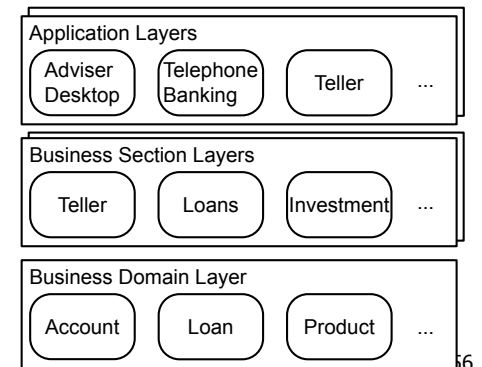
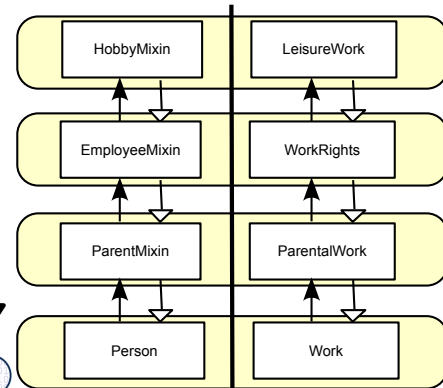

# Layered Mixin Frameworks vs Layered Role Object Frameworks

- ▶ Essentially, layered role object frameworks and layered mixin frameworks provide the same concept for variability and extensibility
- ▶ Difference: mini-connector
  - Layered role object frameworks use as mini-connector the Role Object Pattern
  - Layered mxin frameworks use as mini-connector the GenVoca pattern



# 12.6 How To Find Concerns for a Layered Framework

Example: Layered Frameworks for the Semantic Web



# A New Application Area: Semantic Web Applications

- ▶ Semantic web:
  - Standardization technology for the Web and many application domains
  - Definition of *ontologies*, standard dictionaries
  - Based on inheritance and constraints
- ▶ Every application domain will have its “Semantic Web ontology”
- ▶ How to build product families for those domains?



# The Concerns of an Application in the Semantic Web

- ▶ Which concerns exist?
- ▶ After a little thought: three groups of concerns. (This is not complete, there might be more)

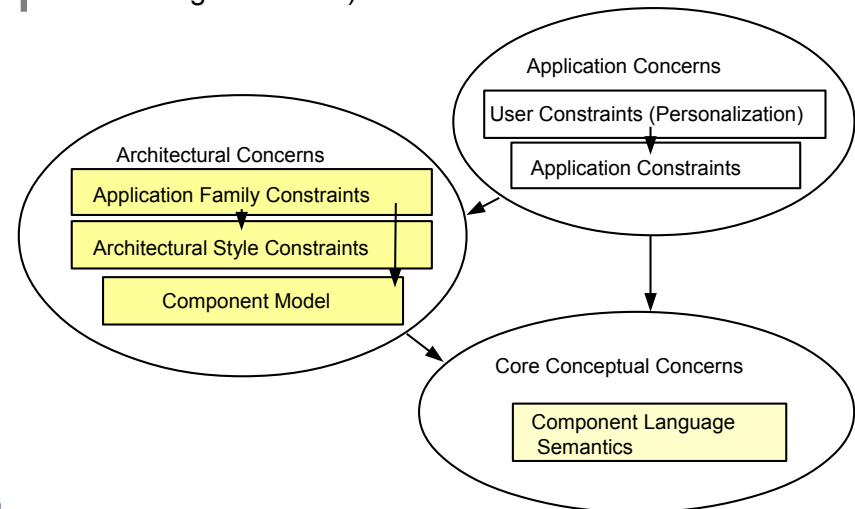

# Layered Frameworks for Product Lines on the Semantic Web

- ▶ We can sort the acyclically dependent concerns into a layered architecture, in which several ComplexObjects crosscut all layers
  - On every level, there are constraints to check the layer for consistency
  - All role objects on the layer are checked by the constraints

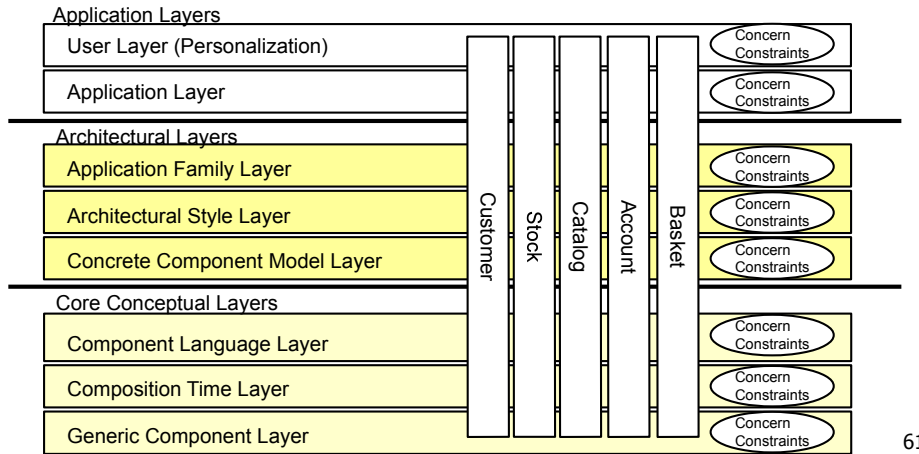

61

# Layered Frameworks for Composition Systems

- ▶ Even a composition system for web applications can be arranged in role layers

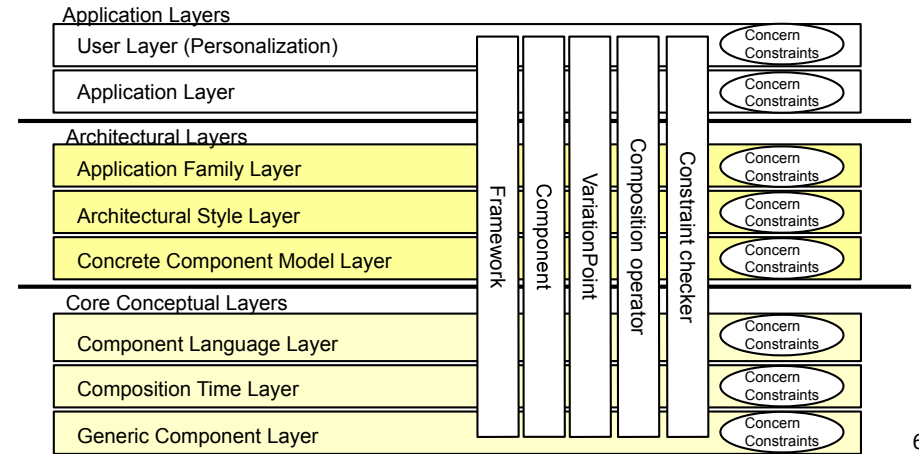

62

# Layers can be Instantiated Differently

- ▶ On every layer of the layered framework, there is variation and extensibility
- ▶ New user constraints
- ▶ New application constraints
- ▶ New application family constraints
- ▶ New architectural constraints
- ▶ New component models
- ▶ New component languages
- ▶ Different Languages in One Framework
  - Since the language is a layer, it can be exchanged
  - Several ontology languages can be used for components in Semantic Web applications
    - BPEL, Datalog, Prolog, OWL

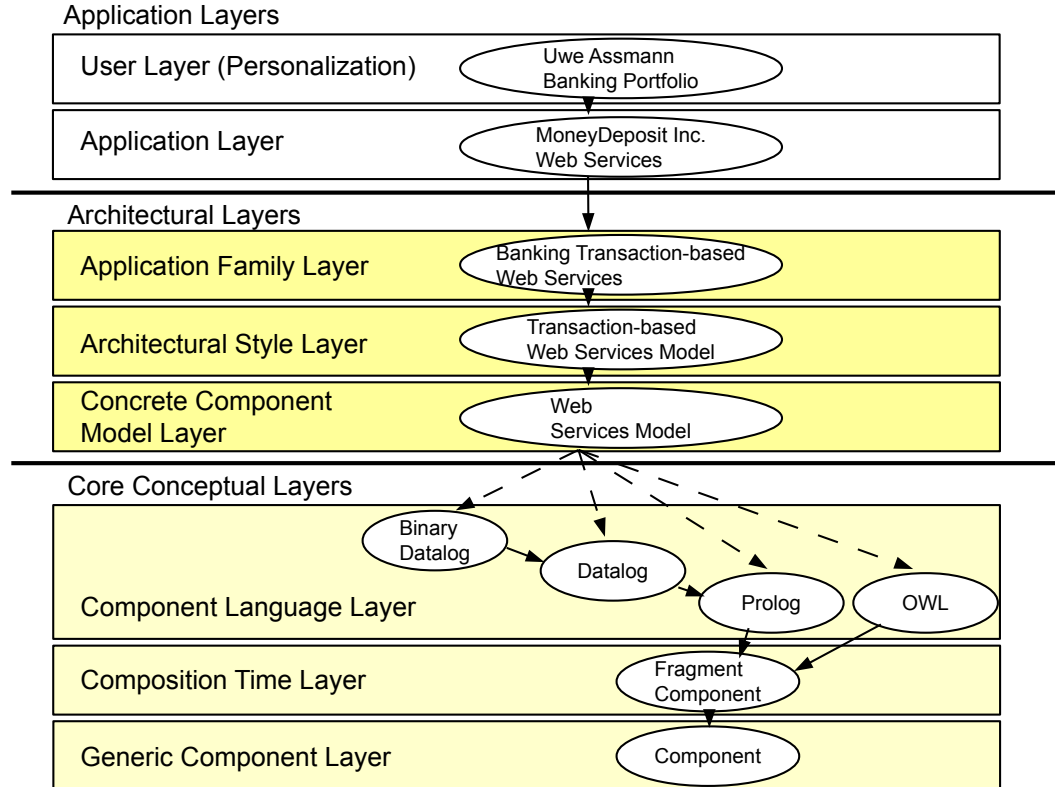

63



# Different Architectures are Possible for One Component Model

- Since the architectural styles can be exchanged for the same component model

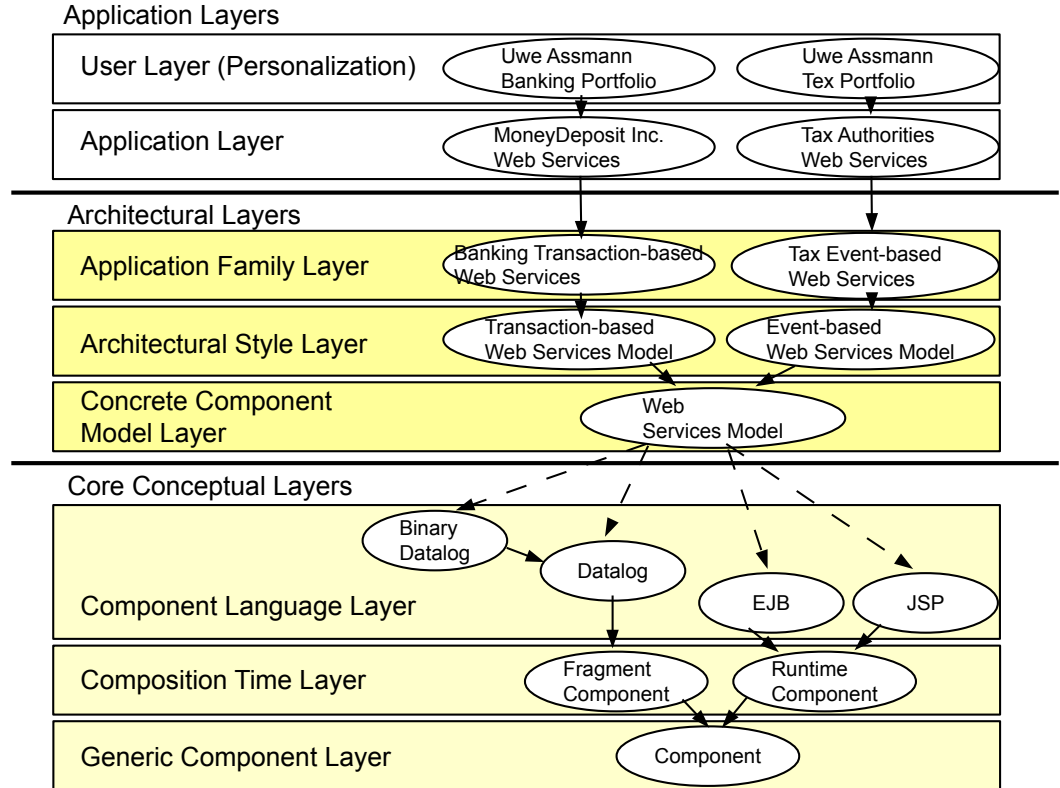

65

# Different Component Models Can Coexist

- Interoperability of Semantic Web application is simplified

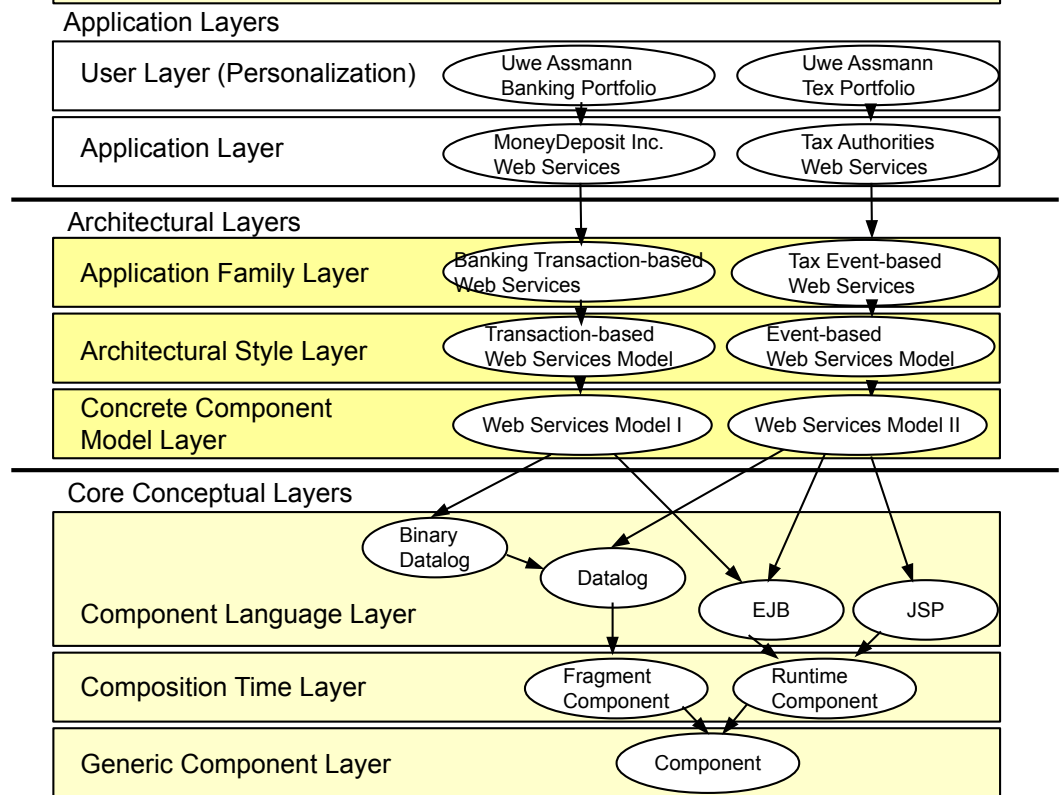

67

# Layered Frameworks and Component Models

- ▶ Once, if languages and component models are layers, layered frameworks can be generalized considerably.
  - Implementation with Layered ROP frameworks or Layered mixin frameworks
- ▶ It becomes possible to build totally heterogeneous applications:
  - Different framework and component languages
  - Different architectures and architectural styles
  - Different product lines (application families)



# What Have We Learned?

- ▶ How can we structure a Product Line as Layered Framework?
  - ExtensionObjects is a simple extension mechanism for frameworks
  - Layered frameworks provide variability and extensibility for thousands of different products in a product line
- ▶ Process for layered frameworks:
  - Identify concerns (abstraction layers), which crosscut all or many objects. These concerns are similar to facets, but not independent
  - Sort them according to their (acyclic) dependencies
  - Use ROP or Genvoca pattern for implementation
  - Use framework role layers or mixin layers for a layered application



# The End

