

## Frameworks

In this exercise we will look at a few frameworks and analyse them for template hook patterns.

### Task 10.1: Hook Fundamentals

1a) **Task:**

What framework hook patterns do you know?

**Solution:** See next sub-task.

1b) **Task:**

Which of these patterns are typical for black-box reuse? Which are typical for white-box reuse?

**Solution:**

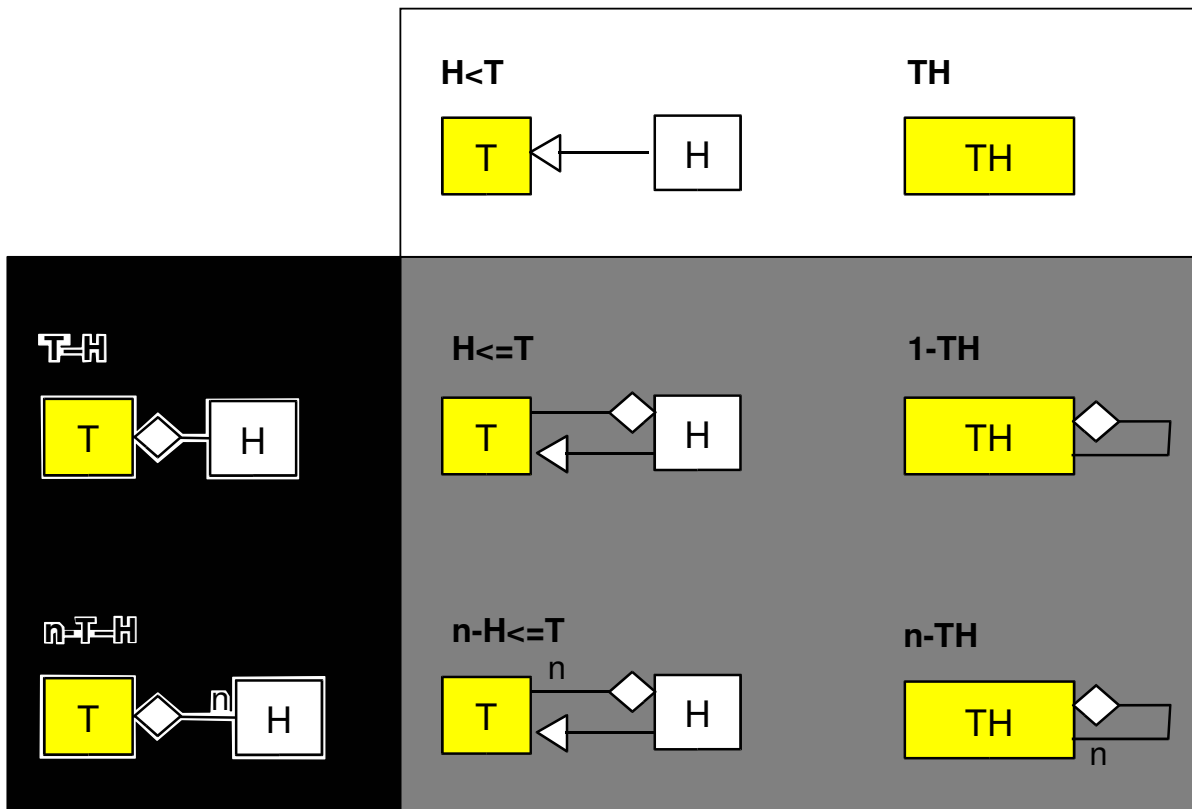

## Task 10.2: Log4J

Log4J is a framework supporting powerful logging statements in Java programs. Check out the framework at <http://logging.apache.org/log4j/1.2/> and understand the core principles.

### 2a) Task:

Look at the classes `Appender` and `Layout` and their relationship. What template–hook pattern can you find here?

**Solution:** There is a  $T-H$  pattern with `Appender` as the template and `Layout` as the hook.

### 2b) Task:

Look at the classes `Logger` and `Appender` and their relationship. What template–hook pattern can you find here?

**Solution:** There is a  $nT-H$  pattern with `Logger` as the template and `Appender` as the hook.

### 2c) Task:

From the hooks you found: What kind of framework is Log4J? Is it rather black-box or white-box?

**Solution:** The hooks are typically of the  $xT-H$  variety; that is they are hooks typical of black-box frameworks.

## Task 10.3: JUnit

JUnit is a framework for unit-testing Java programs in a manner supporting regression tests. While JUnit 4 uses Java annotations for marking specific classes as Test cases, earlier versions of the framework employed various template–hook patterns. Check out version 3.8.1 of the framework at <http://junit.org> and understand the core principles.

### 3a) Task:

Look at the `TestCase` class. What template–hook pattern can you find here?

**Solution:** There is a  $TH$  pattern (equivalent to  $H < T$ ) here. The `run` operation constitutes the template part; `setUp`, `runTest`, and `tearDown` are realised in the hook.

### 3b) Task:

Look at the classes `TestSuite` and `Test` and their relationship. What template–hook pattern can you find here?

**Solution:** There is a  $nT-H$  pattern with `TestSuite` as the template and `Test` as the hook. The interesting bit is that `TestSuite` is a subclass of `Test`, which could mislead one to interpret the hook as a  $nH \leq T$  hook. However, because tests are what you vary, `Test` is the hook, and the pattern is  $nT-H$ .

### 3c) Task:

Look at the classes `TestCase` and `TestResult` and their relationship. What template–hook pattern can you find here?

**Solution:** There is no pattern here at all, because there is no variation point.

### 3d) Task:

From the hooks you found: What kind of framework is JUnit? Is it rather black-box or white-box?

**Solution:** The hooks are typically of the  $xT-H$  variety; that is they are hooks typical of black-box frameworks. However, one of the core hooks (`TestCase`) is a  $TH$  hook, which is the archetypical white-box hook. Therefore, I would say that the framework is somewhere between black and white, but leans more to the white side.