

# 41. Role-Based (Meta-)Modeling

in the Research Training School on  
Role-oriented Software Infrastructures (RoSI)

1. A Primer on Roles
2. Role-based Modeling and Programming Languages
3. The Compartment Role Object Model (CROM)





# The RoSI Research Training Group

## Software Development for continuous-context-sensitive Systems

3

Model-Driven Software Development in Technical Spaces (MOST)

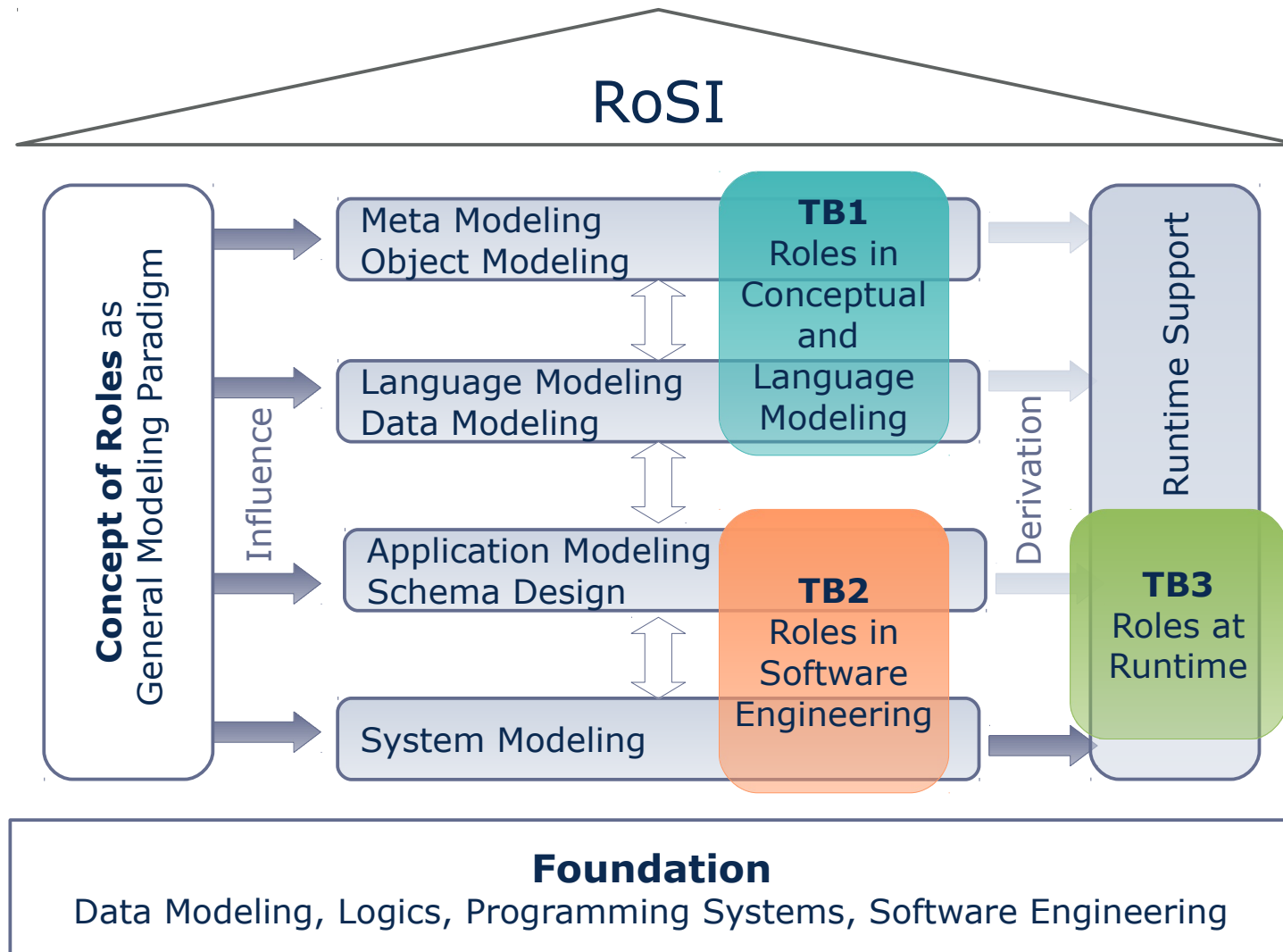

# The RoSI Research Training Group

## Research Areas

4

Model-Driven Software Development in Technical Spaces (MOST)

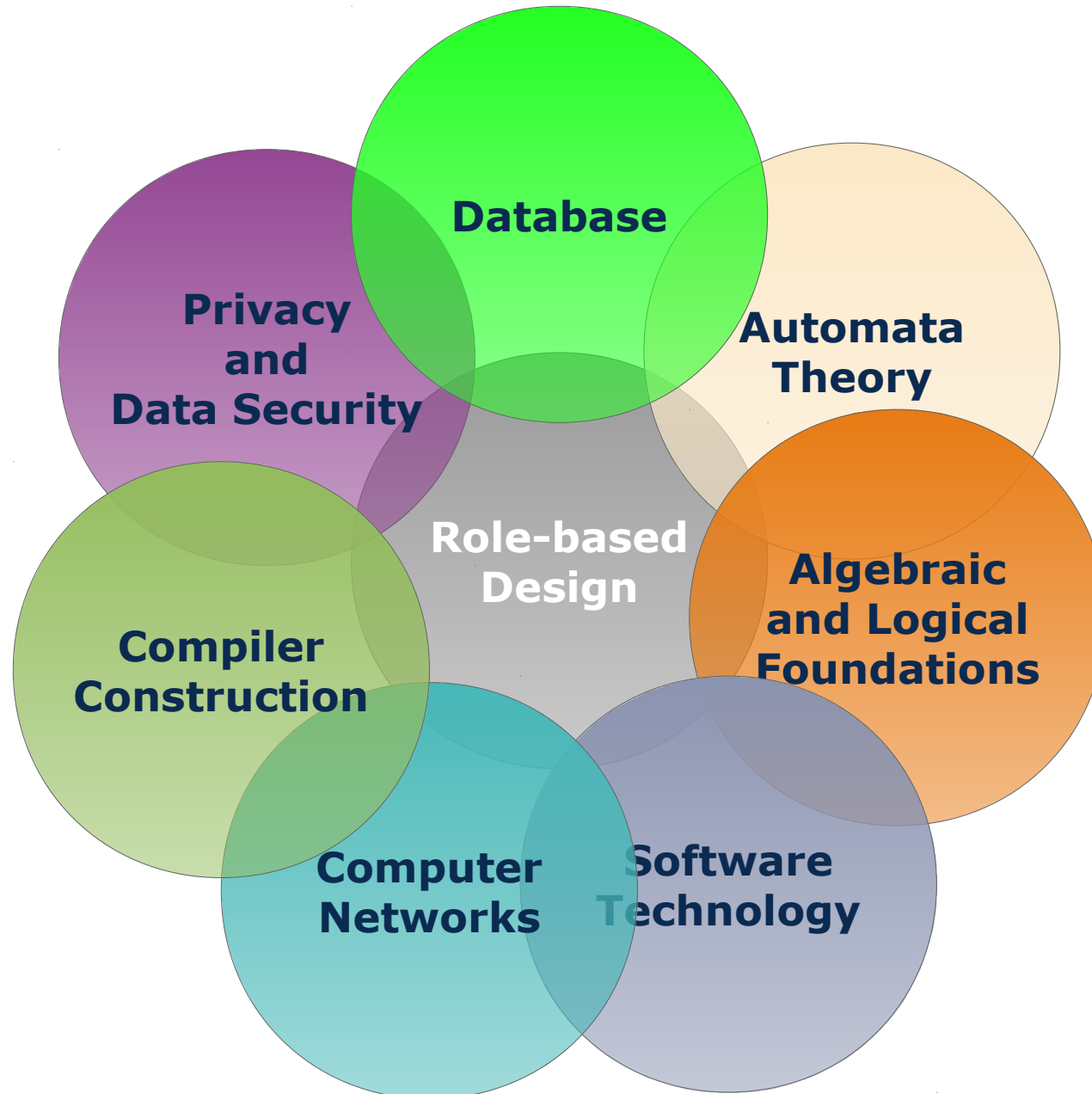

## 41.1. A Primer on Roles

Prof. Dr. Uwe Aßmann

Dr.-Ing. Thomas Kühn

Technische Universität Dresden

Institut für Software- und  
Multimediatechnik

<http://st.inf.tu-dresden.de/teaching/most>

Version 16-1.0, 18.12.17



DRESDEN  
concept  
Exzellenz aus  
Wissenschaft  
und Kultur

# A Primer on Roles

## Basic Roles

6

Model-Driven Software Development in Technical Spaces (MOST)

- ▶ Entities **play** multiple Roles during their lifetime

Examples: *Driver, Doctor, Patient, Student, ...*

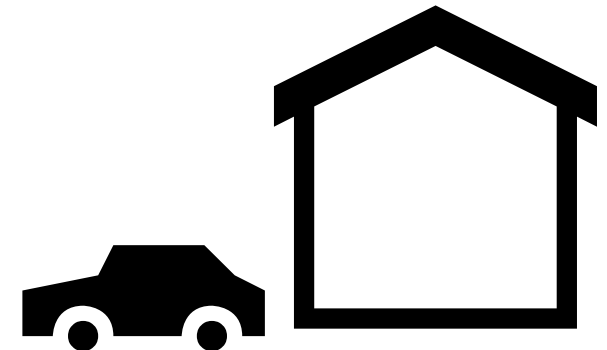
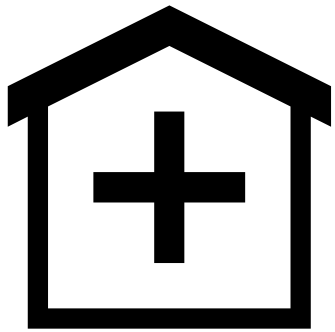

Alice  
Nurse



Bob  
Patient



Gregory  
Doctor



Bob  
Injured



Bob  
Driver

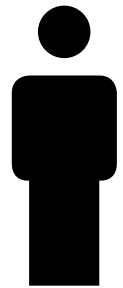

Bob

# A Primer on Roles

## Limitations of Object-Oriented Design

### Supplier/Customer Problem

[Steimann2000]

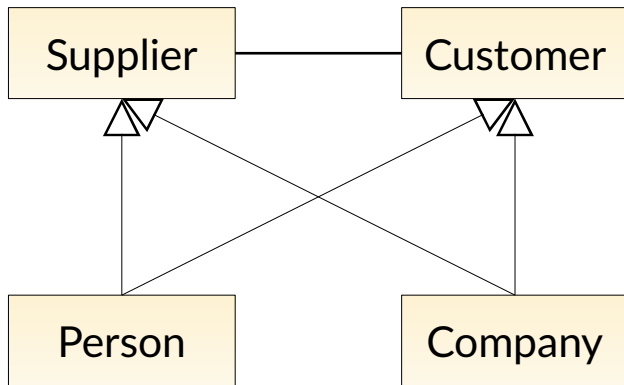

- ▶ Multiple entities fulfill the same roles

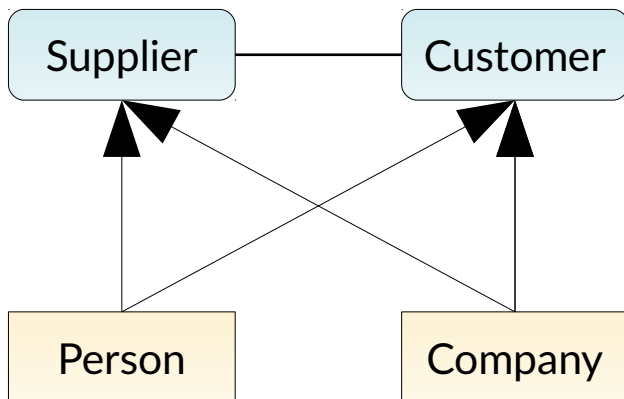

Class

—▷ inheritance

### Multiple Classification

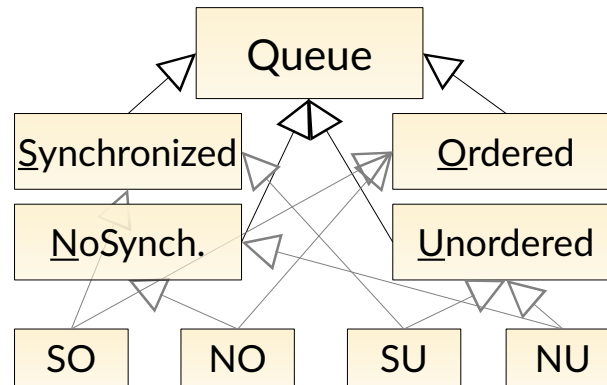

- ▶ Entity subject to multiple classifying features

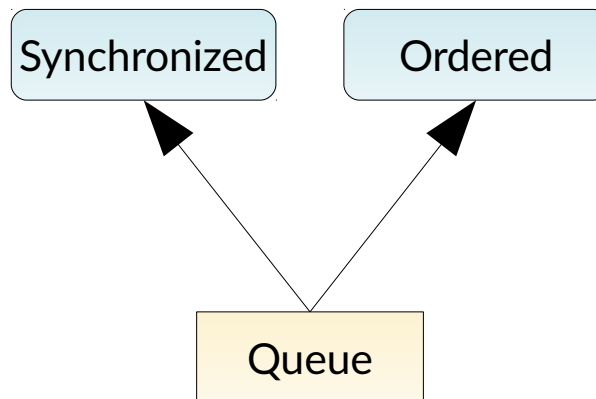

RoleType

—▷ can play

### State-Dependence

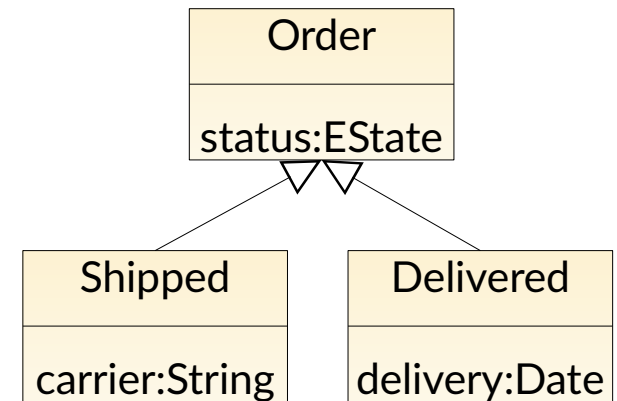

- ▶ Specialization of entity depends on state

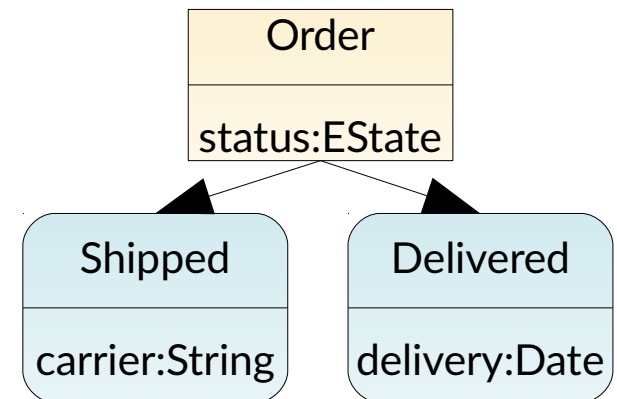

---▷ role implication

# A Primer on Roles

## Context-Dependent Roles

8

Model-Driven Software Development in Technical Spaces (MOST)

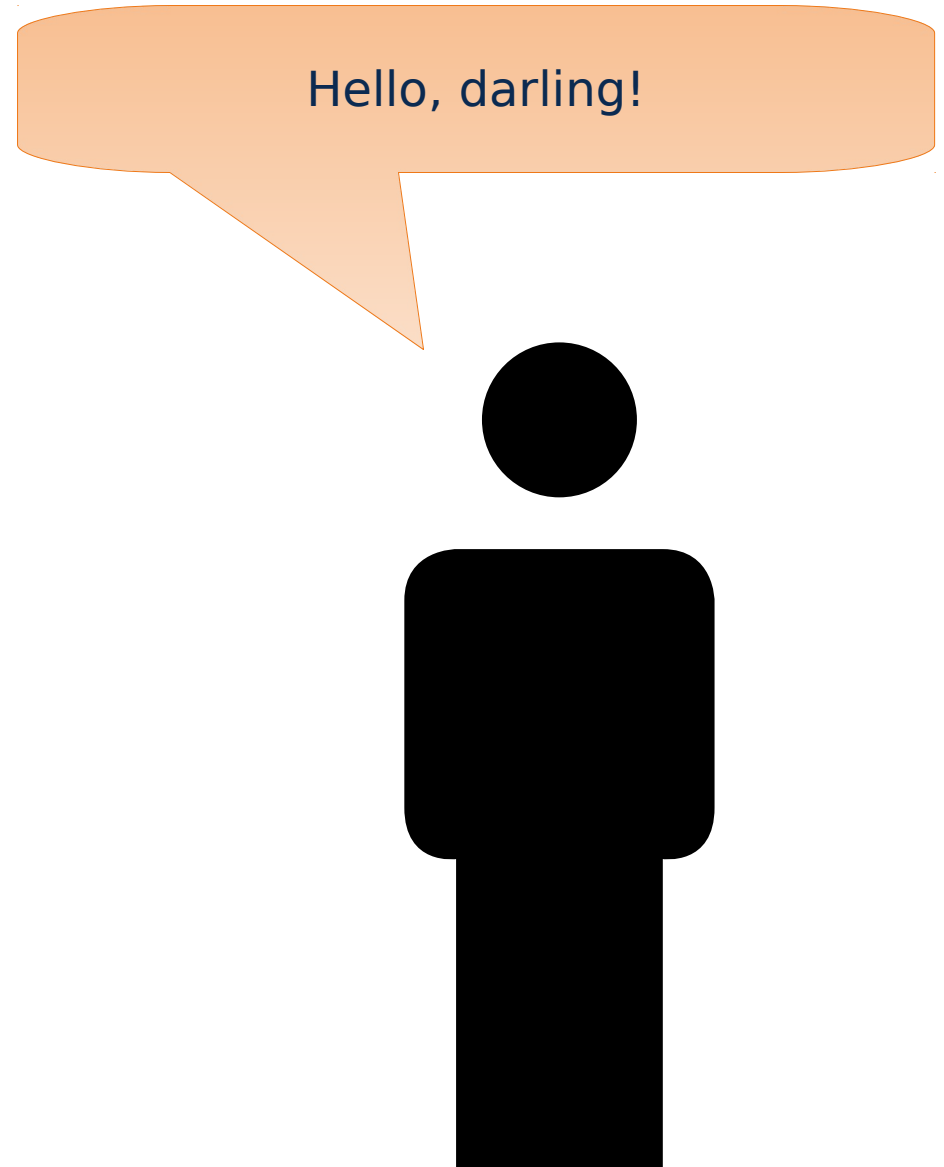
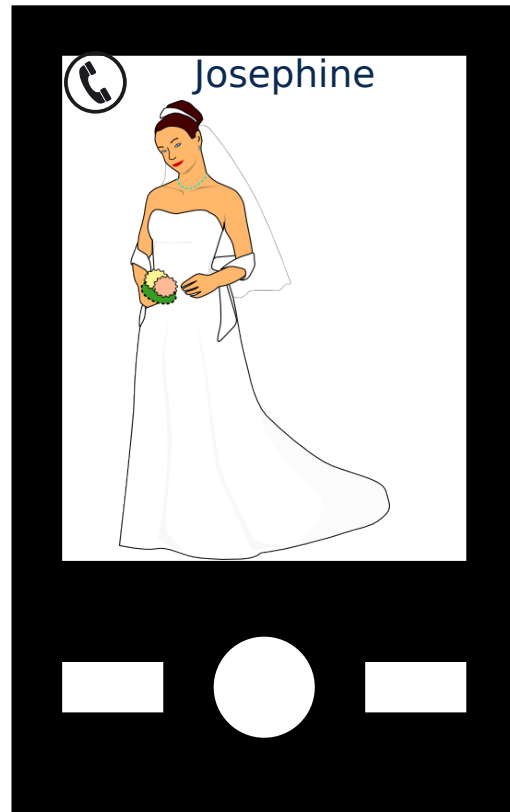
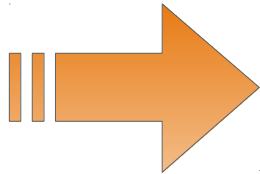

**Context:** Engagement  
**Role:** Wife  
**Co-Role:** Husband



# A Primer on Roles

## Context-Dependent Roles

9

Model-Driven Software Development in Technical Spaces (MOST)

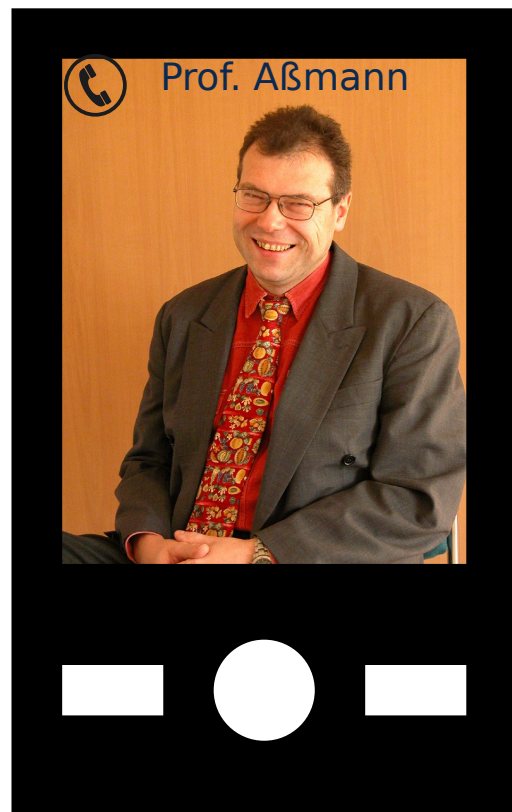
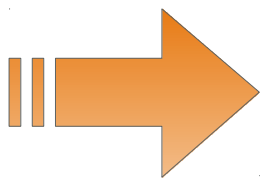

Hello Prof. Aßmann,  
what can I do for you?



**Context:** Chair of Software Technology  
**Role:** Research Assistant  
**Co-Role:** Professor

# A Primer on Roles

## Context-Dependent Roles

10

Model-Driven Software Development in Technical Spaces (MOST)

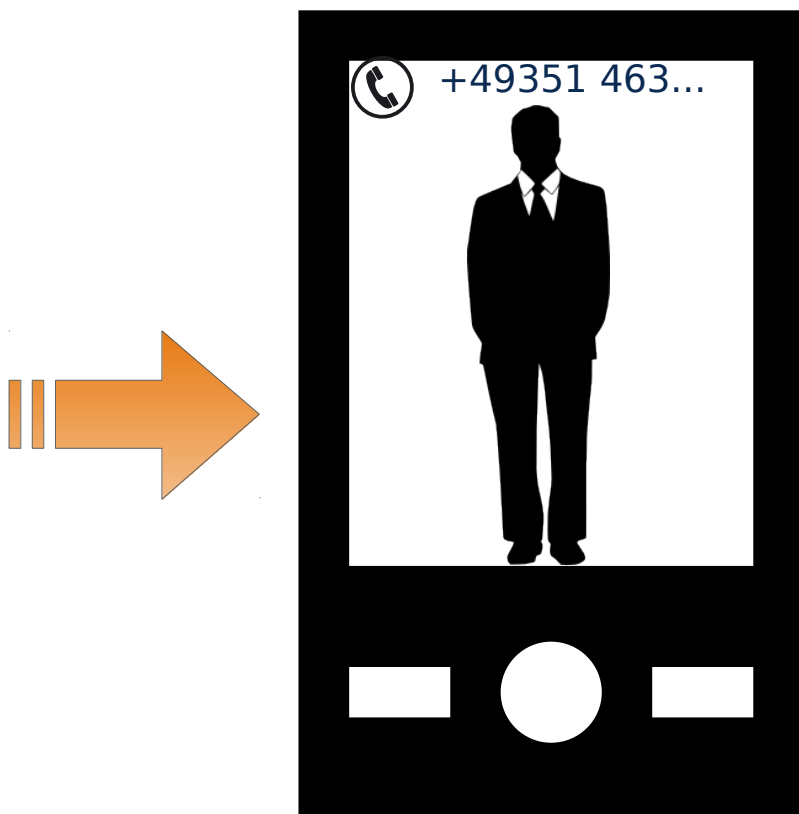

Hello, this is chair of software technology, Thomas Kühn speaking.  
How may I help you?



**Context:** Chair of Software Technology  
**Role:** Called  
**Co-Role:** (Unkown)Caller

# A Primer on Roles

## Context-Dependent Roles

11

Model-Driven Software Development in Technical Spaces (MOST)

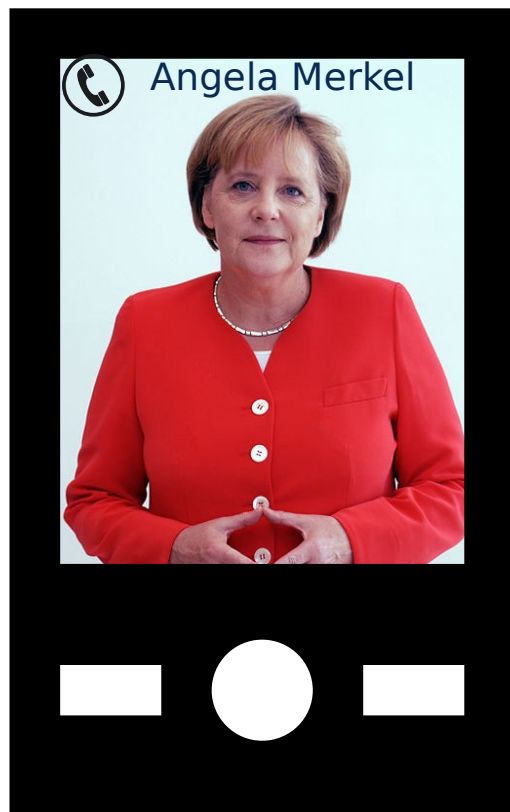
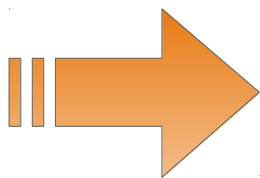

Uh... What... Eh...  
How may I help you?



**Context:** Federal Republic of Germany  
**Role:** Federal Citizen  
**Co-Role:** Chancellor of Germany

# A Primer on Roles

## Summary

- ▶ Role activation **depends** on context of both *Caller* and *Called*
- ▶ Roles can denote **places** in a relationship
- ▶ Each role is **bound** to context (instance)
- ▶ Contexts are hierarchically decomposable
  - May *contain contexts*, but
  - May *overlap*
- ▶ In the literature a context can be:
  - Relationship,
  - Process,
  - Social Individual,
  - Social Institution or
  - Ontology

## 41.2. Roles in Modeling and Programming Languages

Prof. Dr. Uwe Aßmann

Dr.-Ing. Thomas Kühn

Technische Universität Dresden

Institut für Software- und  
Multimediatechnik

<http://st.inf.tu-dresden.de/teaching/most>

Version 16-1.0, 18.12.17



DRESDEN  
concept  
Exzellenz aus  
Wissenschaft  
und Kultur

**[Steimann2000] On the Representation of Roles in Object-Oriented and Conceptual Modelling.**

Friedrich Steimann

*Data & Knowledge Engineering, Elsevier, (2000)*

**[Kühn2014] A Metamodel Family for Role-based Modelling and Programming Languages**

T. Kühn, M. Leuthäuser, S. Götz, C. Seidl, and U. Aßmann

Software Language Engineering SLE'14, Springer (2014)

**[Kühn2017] A Family of Role-Based Languages**

T. Kühn

Dissertation, Technische Universität Dresden, Fakultät Informatik (2017)

- [Bachman1977] **The Role Concept in Data Models.** Charles W. Bachman and Manilal Daya. *VLDB (1977)*
- [Balzer2007] **A Relational Model of Object Collaborations and its Use in Reasoning about Relationships.** S. Balzer, T. Gross, and P. Eugster. *ECOOP, vol. 4609 of LNCS (2007)*
- [Barbosa2012] **Modeling and Programming with Roles: introducing JavaStage.** F.S. Barbosa and A. Aguiar. *Tech.Rep., Instituto Polit´cnico de Castelo Branco (2012)*
- [Burmester2005] **Model-Driven Development of Reconfigurable Mechatronic Systems with Mechatronic UML.** S. Burmester, G. Holger, and M. Tichy. *Model Driven Architecture, Springer, 2005*
- [Carrington2004] **Using Integrated Metamodeling to Define OO Design Patterns with Object-Z and UML.** S.-K. Kim and D. Carrington. *11th Asia-Pacific Software Engineering Conference, IEEE (2004)*
- [Dahchour2002] **A Generic Role Model for Dynamic Objects.** M. Dahchour et al. *Advanced Information Systems Engineering, Springer (2002)*
- [Genovese2007] **A meta-model for roles: Introducing sessions.** V. Genovese. *Roles' 07 (2007)*
- [Graversen2003] **Implementation of a Role Language for Object-Specific Dynamic Separation of Concerns.** K.B. Graversen and K. Østerbye. *AOSD03 Workshop (2003)*
- [Halpin2005] **ORM 2.** T. A. Halpin. *OTM Workshops, vol. 3762 of LNCS (2005)*
- [He2006] **Rava: Designing a Java Extension with Dynamic Object Roles.** Chengwan He, et al. *13th Annual IEEE International Symposium and Workshop (2006)*
- [Hennicker2014] **Foundations for Ensemble Modeling The HELENA Approach.** R. Hennicker and A. Klarl. *Specification, Algebra, and Software, Springer (2014)*

- [Kamina2009] **Towards Safe and Flexible Object Adaptation.** Tetsuo Kamina and Tetsuo Tamai. *International Workshop on COP (2009)*
- [Kim2002] **Using Role-Based Modeling Language (RBML) to Characterize Model Families.** D.-K. Kim, R. France, S. Ghosh, and E. Song. *Engineering of Complex Computer Systems, IEEE, 2002*
- [Klarman2010] **ALC<sub>ALC</sub>: A Context Description Logic.** S. Klarman and V. Gutiérrez-Basulto. *Workshop on Logics in Artificial Intelligence, Springer (2010)*
- [Liu2009] **Information Networking Model.** M. Liu and J. Hu. *Conceptual Modeling - ER (2009)*
- [Reenskaug2009] **The DCI Architecture: A New Vision of Object-oriented Programming.** T. Reenskaug and J. O. Coplien. [http://www.artima.com/articles/dci\\_vision.html](http://www.artima.com/articles/dci_vision.html) (2009)
- [Selçuk2004] **JAWIRO: Enhancing Java with Roles.** Y. E. Selçuk and N. Erdogan. *Symposium on Computer and Information Sciences, Springer (2004)*
- [Silva2003] **Taming Agents and Objects in Software Engineering.** V. Da Silva, A. Garcia, A. Brandão, C. Chavez, C. Lucena, and P. Alencar. *Workshop on SE for Large-Scale MAS, Springer (2003)*
- [Zhu2006] **Role-Based Collaboration and its Kernel Mechanisms.** H. Zhu and M. Zhou. *IEEE Transactions 36(4) (2006)*



*„All the world's a **stage**, and all the men and women merely **players**:  
they have their **exits** and their **entrances**;  
and one man in his time **plays many parts**, his acts being seven ages.“*

– William Shakespeare

## The Role Concept

- ▶ *Relatively old, e.g. Bachman and Daya [Bachmann1977]*
- ▶ *Since then many different approaches emerged [Kühn2017]*
- ▶ *No common understanding (or formalism) for roles*

**Each approach can be classified along design decisions**

# Roles in Modeling and Programming Languages

## Initial Classifying Features of Roles

18

Model-Driven Software Development in Technical Spaces (MOST)

	<b>Feature</b>	<b>Metalevel</b>
<b>Behavioral</b>	(1) Roles have properties and behaviors	(M1,M0)
	(2) Roles depend on relationships	(M1,M0)
	(3) An object may play different roles simultaneously	(M1,M0)
	(4) An object may play the same role (type) several times	(M0)
	(5) An object may acquire and abandon roles dynamically	(M0)
	(6) Sequence of role acquisition and removal may be restricted	(M1,M0)
	(7) Unrelated objects can play the same role	(M1)
<b>Relational</b>	(8) Roles can play roles	(M1,M0)
	(9) Roles can be transferred between objects	(M0)
	(10) The state of an object can be role-specific	(M0)
	(11) Features of an object can be role-specific	(M1)
	(12) Roles restrict access	(M0)
	(13) Different roles may share structure and behavior	(M1)
	(14) An object and its roles share identity	(M0)
	(15) An object and its roles have different identities	(M0)

– Friedrich Steimann [Steimann2000]

# Roles in Modeling and Programming Languages

## Additional Classifying Features of Roles

<b>Feature</b>	<b>Metalevel</b>
(16) Relationships between Roles can be constrained	(M1)
(17) There may be constraints between relationship	(M1)
(18) Roles can be grouped and constrained together	(M1)
(19) Roles depend on contexts	(M1,M0)
(20) Contexts have properties and behaviors	(M1,M0)
(21) A role can be part of several contexts	(M1,M0)
(22) Contexts may play roles like objects	(M1,M0)
(23) Contexts may play roles which are part of themselves	(M1,M0)
(24) Contexts can contain other contexts	(M1,M0)
(25) Different contexts may share structure and behavior	(M1)
(26) Contexts have their own identity	(M0)
(27) The number of roles occurring in a context can be constrained	(M1)

- Kühn et al. [Kühn2000]

# Roles in Modeling and Programming Languages

## Natures of Roles

**Relational**

Roles are named places of **relationships**

Roles **adapt** the behavior of playing objects

**Behavioral**

**Context-Dependent**

Roles can capture **context-dependent** properties of objects

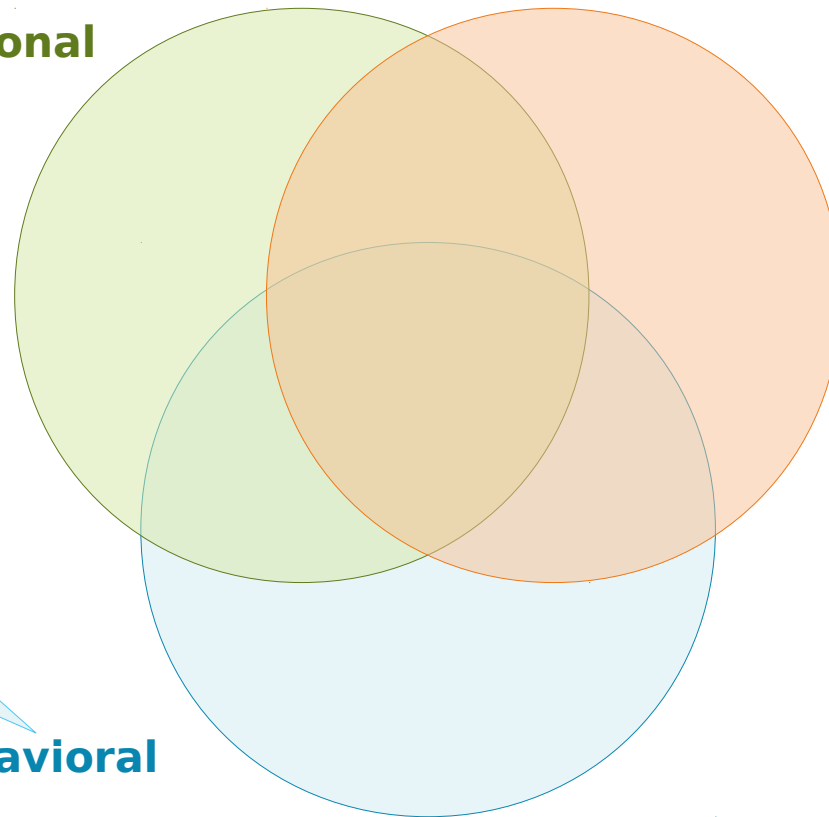

# Roles in Modeling and Programming Languages

## Literature Survey [Kühn2014,Kühn2017]

- ▶ *Structured Literature Review* of publications since 2000
- ▶ Published by the big four (i.e., *Springer, IEEE, ACM, Science Direct*)

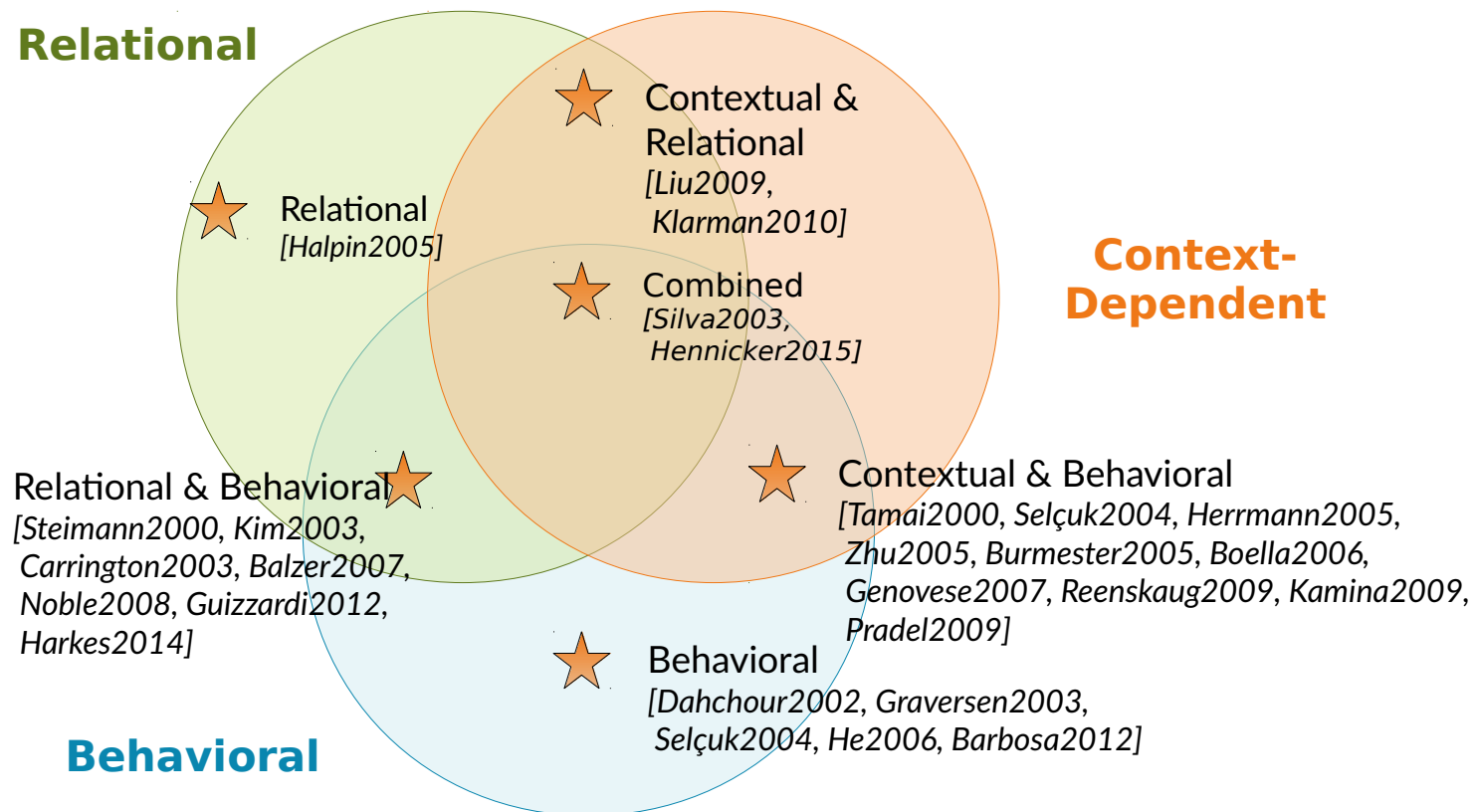

**Research Field suffers from fragmentation and discontinuity**

# Roles in Modeling and Programming Languages

## Selected Relational Modeling Languages

### LODWICK's UML Notation [Steimann2000]

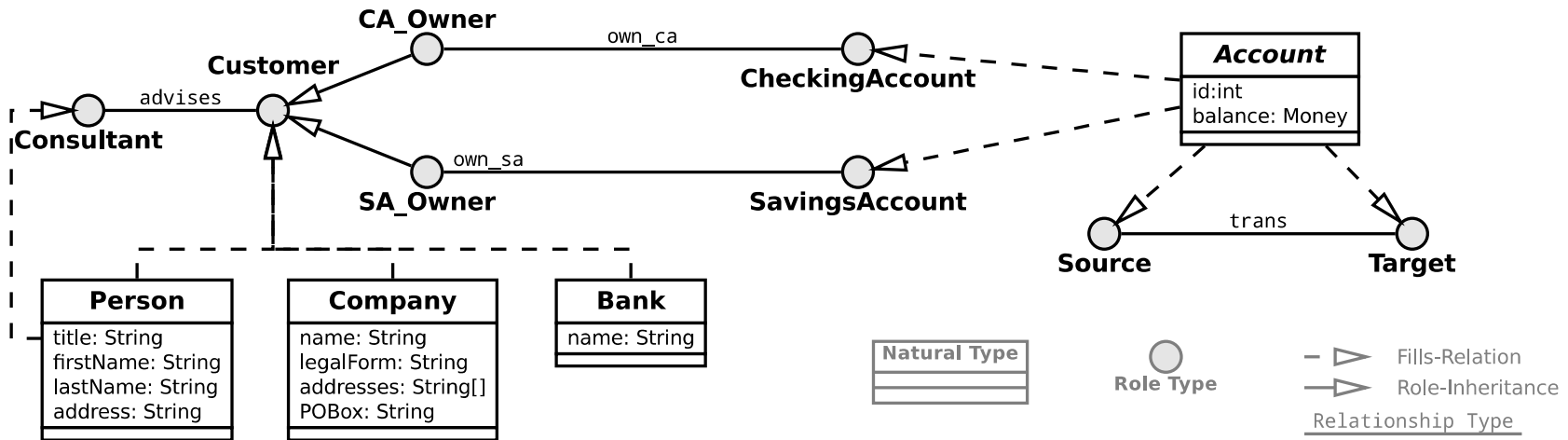

### Object-Role Modeling (ORM) 2 [Halpin2005]

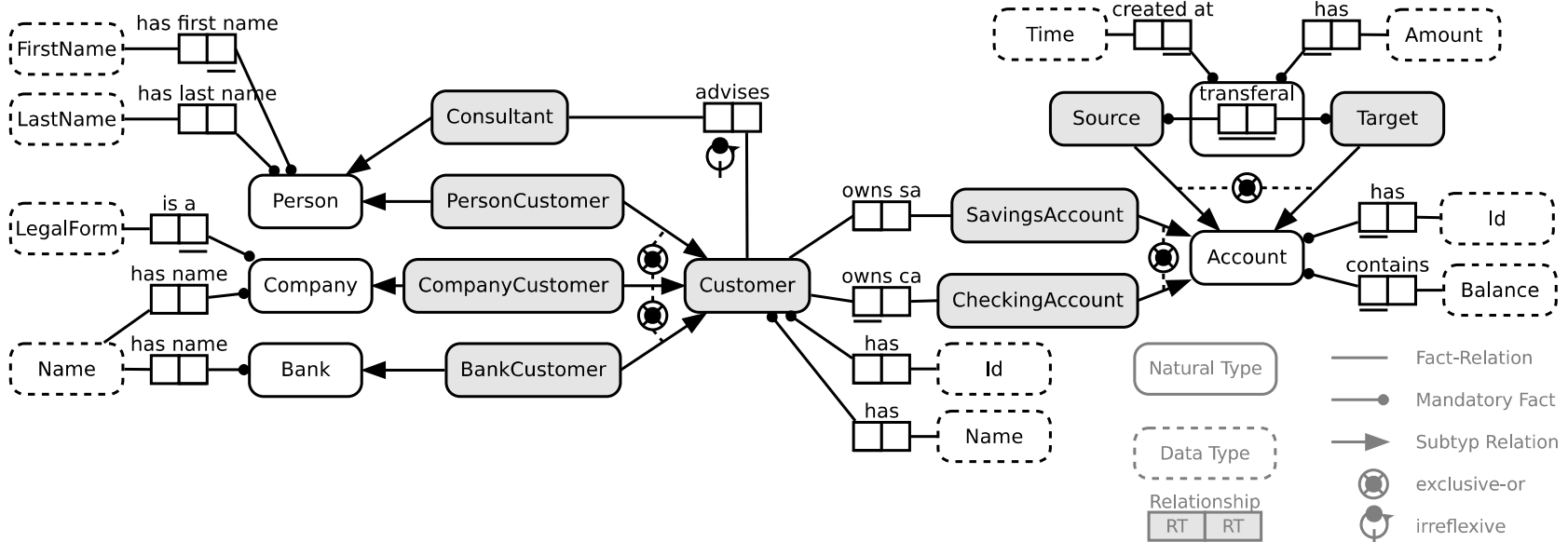

# Roles in Modeling and Programming Languages

## Selected Relational and Behavioral Modeling Languages

### OntoUML [Guizzardi2012]

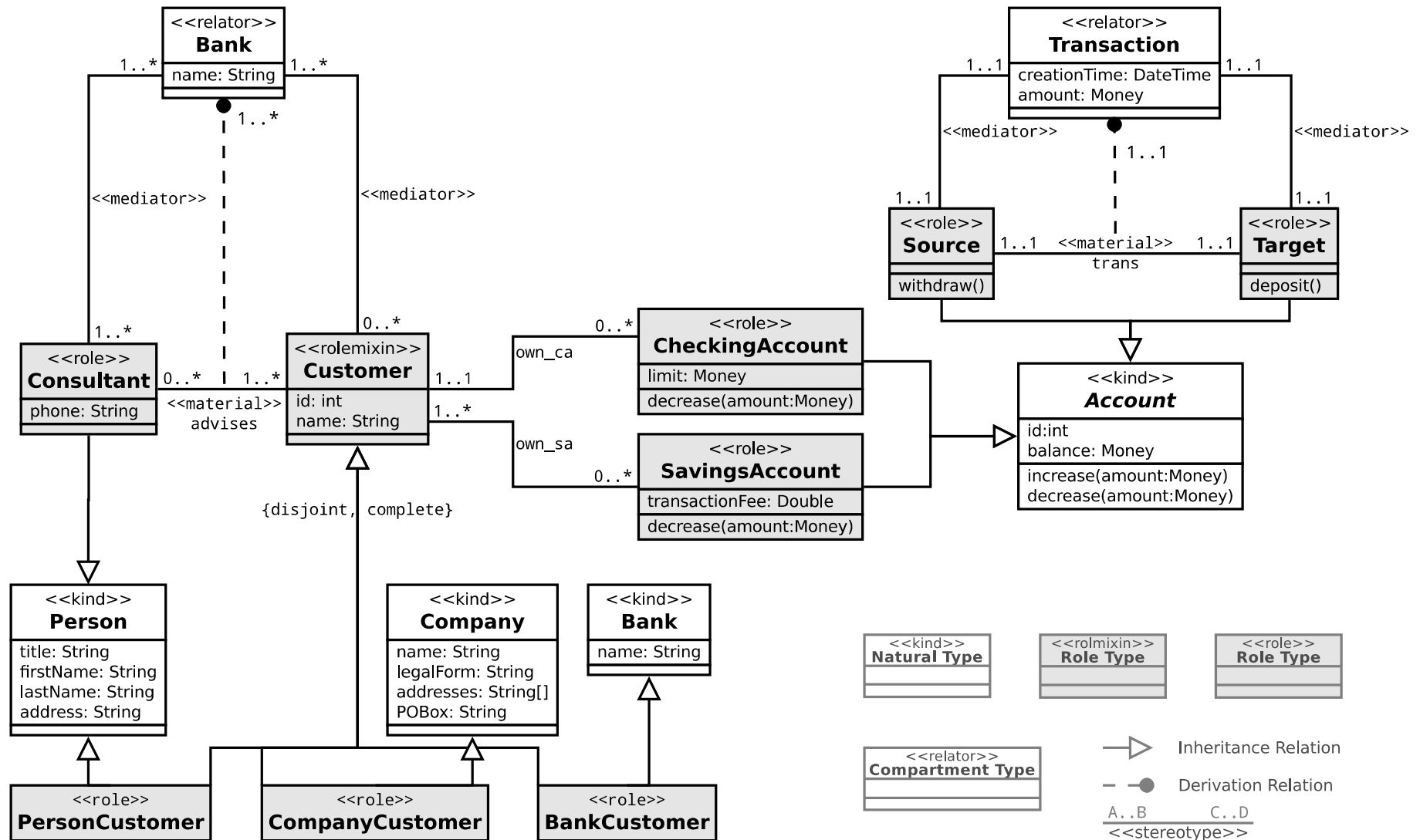

# Roles in Modeling and Programming Languages

## Selected Contextual and Relational Modeling Languages

### Information Network Model (INM) [Liu2009]

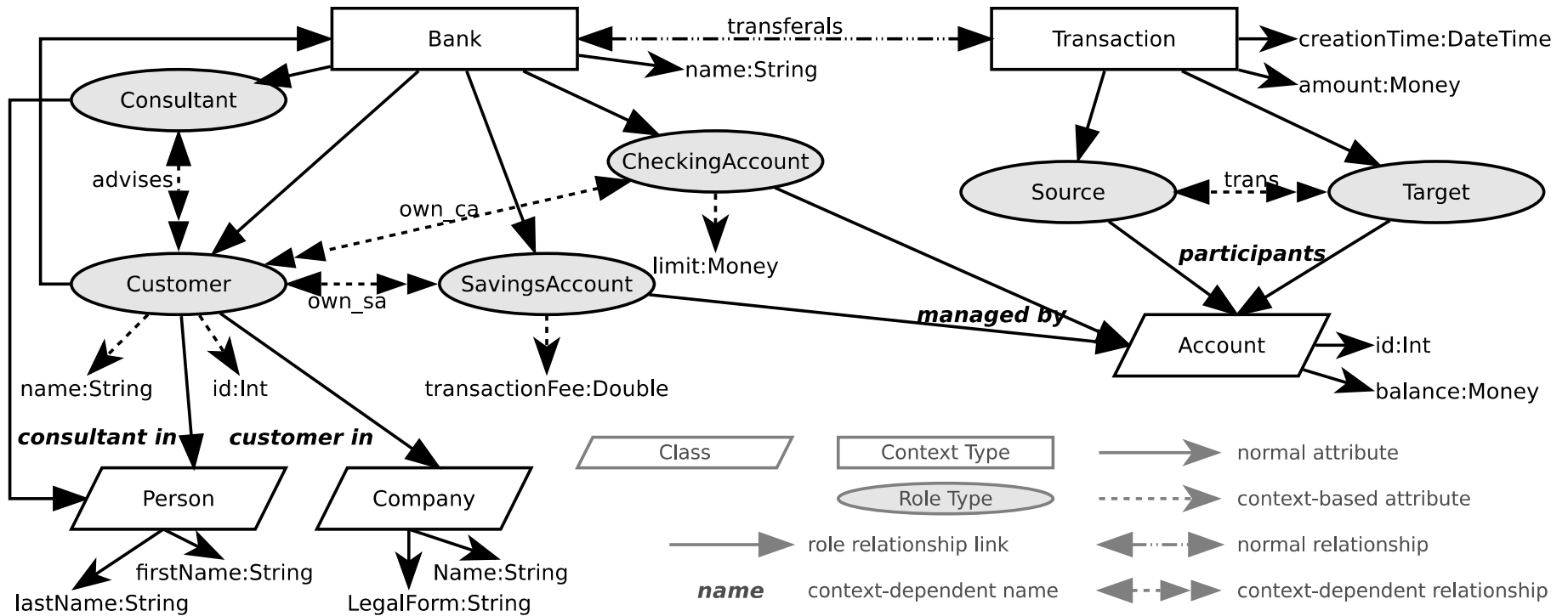



# Roles in Modeling and Programming Languages

## Selected Combined Modeling Languages

### Taming Agents and Objects (TAO) [Silva2003]

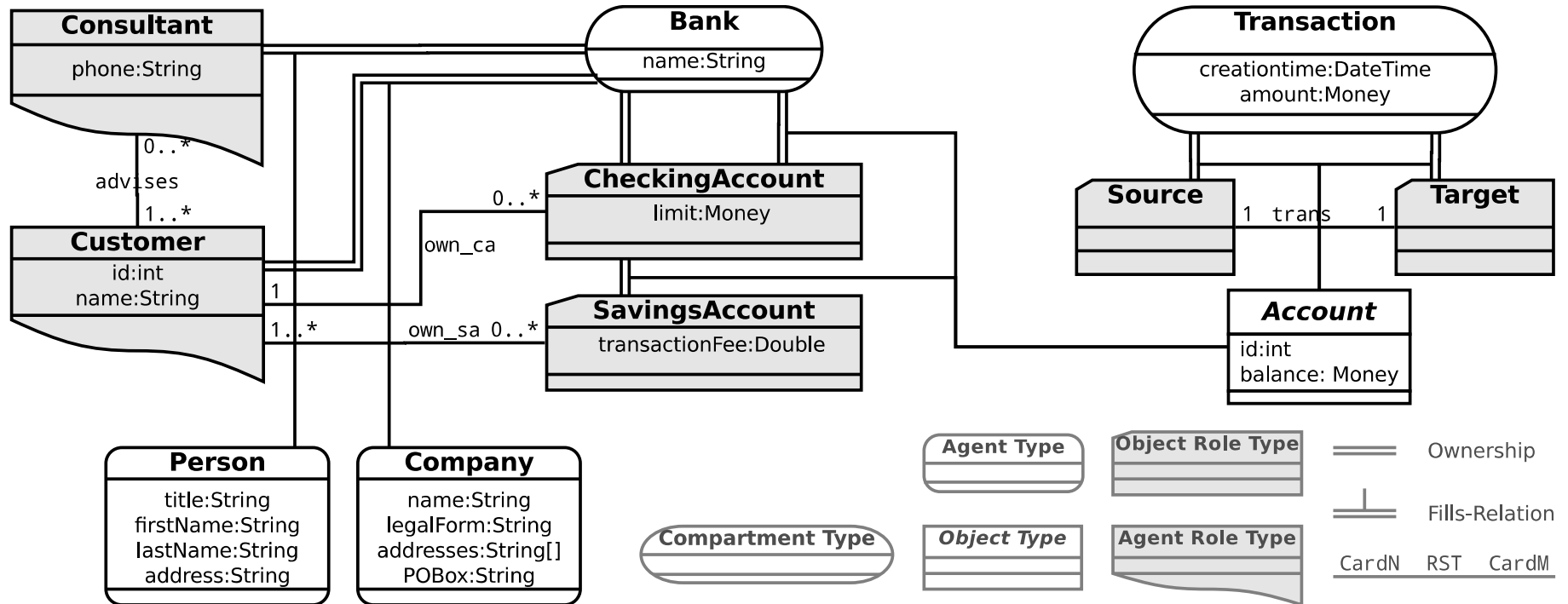

# Roles in Modeling and Programming Languages

## Selected Combined Modeling Languages

### The HELENA Approach [Hennicker2015]

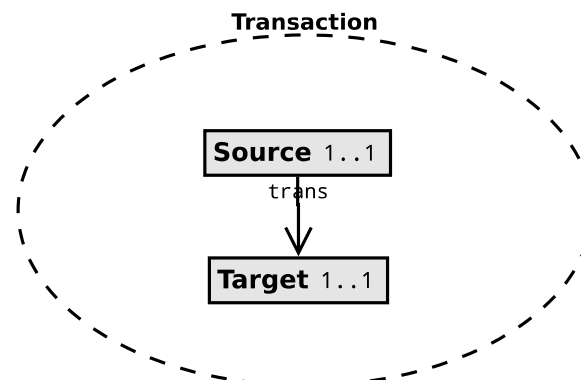
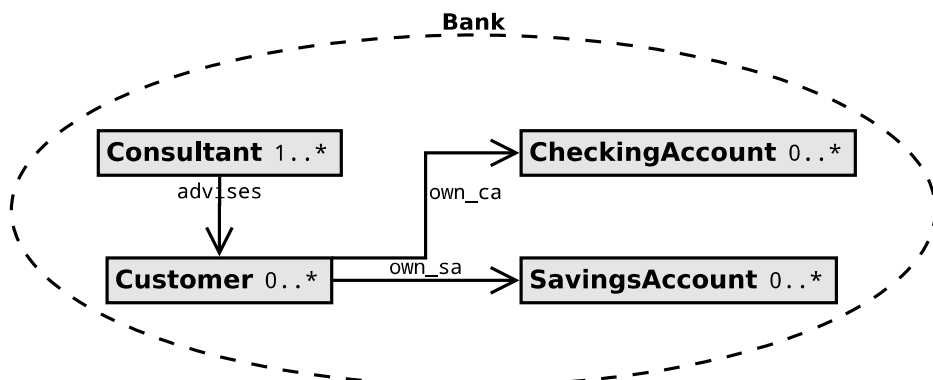

<<role connector type>> <b>advises</b>
src Consultant trg Customer

<<role connector type>> <b>own_ca</b>
src Customer trg CheckingAccount

<<role connector type>> <b>own_sa</b>
src Customer trg SavingsAccount

<<role connector type>> <b>trans</b>
src Source trg Target deposit(amount:Money)

<<role type>> <b>Customer: {Person,Company}</b>
id: int name: String

<<role type>> <b>Consultant: {Person}</b>
phone: String

<<role type>> <b>Source: {Account}</b>
withdraw(amount:Money)

<<role type>> <b>Target: {Account}</b>
deposit(amount:Money)

<<role type>> <b>CheckingAccount: {Account}</b>
limit: Money increase(amount:Money) decrease(amount:Money)

<<role type>> <b>SavingsAccount: {Account}</b>
transactionFee: Double increase(amount:Money) decrease(amount:Money)

<<component type>> <b>Person</b>
title: String firstName: String lastName: String address: String

<<component type>> <b>Company</b>
name: String legalForm: String addresses: String[] POBox: String

<<component type>> <b>Account</b>
id:int balance: Money

<<component type>> <b>Natural Type</b>
---

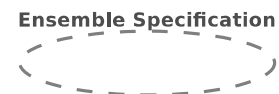

<<role type>> <b>Role Type: {Player}</b>
---

<<role connector type>> <b>Relationship Type</b>
---



# Roles in Modeling and Programming Languages

## Comparison (1)

Features 2014	Lodwick 2000	Generic Role Model 2002	TAO 2003	RBML 2003	Role-Based Patterns 2004	ORM 2 2005	E-CARGO 2006	Metamodel for Roles 2007	INM 2009	DCI 2009	OntoUML 2012	Helena Approach 2014
1	■	■	■	■	■	▣	▣	■	■	■	■	■
2	■	□	■	■	■	■	□	▣	■	▣	■	■
3	■	■	■	■	■	■	■	▣	■	■	▣	■
4	■	■	■	■	□	■	■	■	■	□	∅	■
5	■	■	∅	∅	∅	■	■	■	∅	▣	∅	■
6	▣	■	∅	∅	■	▣	▣	∅	□	□	□	□
7	■	□	■	□	□	▣	▣	■	□	■	▣	■
8	□	■	□	□	□	□	□	■	■	□	■	□
9	▣	□	▣	∅	∅	∅	■	▣	∅	□	∅	□
10	▣	■	■	∅	□	∅	▣	▣	■	■	■	■
11	▣	■	■	□	■	□	□	▣	■	■	■	■
12	∅	▣	▣	■	∅	∅	■	∅	∅	■	∅	■
13	▣	■	■	■	■	□	□	■	■	▣	▣	□
14	■	□	□	■	■	■	■	▣	■	▣	■	□
15	□	■	■	□	□	□	▣	▣	□	▣	□	■

■: yes, ▣: possible, □: no, ∅: not applicable

**Role-Based Modeling Languages**

Features 2014	EpsilonJ 2001	Chameleon 2003	RICA-J 2004	JAWIRO 2004	OT/J 2005	Rava 2006	powerJava 2006	Rumer 2007	First-Class Relationships 2008	Scala Roles 2009	NextEJ 2009	JavaStage 2012	Relations 2014
1	■	■	■	■	■	■	■	■	■	■	■	■	□
2	▣	□	□	□	▣	□	▣	■	■	▣	▣	□	■
3	■	■	■	■	■	■	■	■	■	■	■	■	■
4	■	■	□	■	■	□	■	■	■	■	■	▣	■
5	■	■	■	■	■	■	■	■	■	■	■	□	∅
6	□	□	▣	▣	■	□	▣	■	□	□	□	■	▣
7	■	□	■	■	□	■	□	▣	□	■	■	■	□
8	■	□	■	■	■	□	■	□	□	■	■	■	□
9	■	■	□	■	□	□	■	□	□	■	■	□	□
10	■	■	■	■	■	■	■	■	■	■	■	■	□
11	■	■	■	■	■	■	■	■	■	■	■	■	□
12	■	■	■	■	■	■	■	■	□	■	■	■	∅
13	□	□	■	■	■	■	■	□	□	■	□	■	□
14	▣	▣	□	▣	▣	□	□	■	■	■	▣	□	■
15	■	■	■	■	■	■	■	□	□	■	■	■	□

■: yes, ▣: possible, □: no, ∅: not applicable

**Role-Based Programming Languages**

Roles depend on Relationships

Roles played by unrelated Objects



# Roles in Modeling and Programming Languages Comparison (2)

Roles depend on Contexts

Features 2014	Lodwick 2000	Generic Role Model 2002	TAO 2003	RBML 2003	Role-Based Patterns 2004	ORM 2 2005	E-CARGO 2006	Metamodel for Roles 2007	INM 2009	DCI 2009	OntoUML 2012	Helena Approach 2014
16	■	□	■	■	■	■	□	□	□	□	■	□
17	□	□	□	□	□	■	□	□	□	□	■	□
18	□	□	□	□	□	□	⊞	□	□	□	□	□
19	⊞	□	■	□	□	⊞	■	■	■	■	⊞	■
20	□	□	■	□	□	⊞	□	■	■	■	■	■
21	⊞	□	□	□	□	□	■	■	⊞	□	■	■
22	□	□	■	□	□	■	□	■	■	■	□	□
23	□	□	□	□	□	□	□	■	□	□	□	□
24	□	□	■	□	□	□	□	□	■	□	□	□
25	□	□	■	□	□	□	□	■	■	⊞	□	□
26	□	□	■	□	□	■	■	⊞	■	■	□	■
27	□	□	□	■	■	□	■	⊞	□	□	⊞	■

■: yes, ⊞: possible, □: no, ∅: not applicable

## Role-Based Modeling Languages

Features 2014	EpsilonJ 2001	Chameleon 2003	RIC-A-J 2004	JAWIRO 2004	OT/J 2005	Rava 2006	powerJava 2006	Rumer 2007	First-Class Relationships 2008	Scala Roles 2009	NextEJ 2009	JavaStage 2012	Relations 2014
16	□	□	□	□	□	□	□	■	□	□	□	□	□
17	□	□	□	□	□	□	□	□	□	□	□	□	□
18	□	□	□	□	■	□	□	⊞	□	□	□	□	□
19	■	□	■	□	■	□	■	⊞	⊞	■	■	□	■
20	■	□	■	□	■	□	■	■	■	■	■	□	■
21	□	□	□	□	□	□	⊞	□	□	□	□	□	□
22	■	□	□	□	■	□	■	■	□	■	■	□	■
23	□	□	□	□	■	□	□	□	□	⊞	□	□	□
24	⊞	□	□	□	■	□	■	■	□	■	■	□	⊞
25	□	□	■	□	■	□	⊞	□	■	■	□	□	□
26	■	□	■	□	■	□	■	■	■	■	■	□	■
27	⊞	□	□	□	⊞	□	□	□	□	□	⊞	□	■

■: yes, ⊞: possible, □: no, ∅: not applicable

## Role-Based Programming Languages



# Roles in Modeling and Programming Languages

## Summary

- ▶ **Discontinuity** and **fragmentation** of research field
- ▶ Insufficient **formal foundation** for role-based languages
- ▶ **No** language supports **all** features of roles and modeling constraints
- ▶ Only few languages provide **tool support**, most rely on UML stereotypes
- ▶ **No** family of role-based language for **all** language variants

## 41.3. The Compartment Role Object Model (CROM)

Prof. Dr. Uwe Aßmann

Dr.-Ing. Thomas Kühn

Technische Universität Dresden

Institut für Software- und  
Multimediatechnik

<http://st.inf.tu-dresden.de/teaching/most>

Version 16-1.0, 18.12.17



DRESDEN  
concept  
Exzellenz aus  
Wissenschaft  
und Kultur

**[Kühn2015] A Combined Formal Model for Relational Context-Dependent Roles**

T. Kühn, S. Böhme, S. Götz and U. Aßmann

Software Language Engineering *SLE'15, ACM (2015)*

**[Kühn2016] FRaMED: Full-Fledge Role Modeling Editor (Tool Demo)**

T. Kühn, K. Bierzynski, S. Richly, and U. Aßmann

Software Language Engineering *SLE'16, ACM (2016)*

- [Leuthäuser2015] **Enabling View-based Programming with SCROLL: Using Roles and Dynamic Dispatch for Establishing View-based Programming.** Max Leuthäuser and Uwe Aßmann. *MORSE/VAO '15, ACM (2015)*
- [Jäkel2016] **Towards a Contextual Database.** T. Jäkel, T. Kühn, H. Voigt, and W. Lehner. *ADBIS (2016)*
- [Böhme2017] **Reasoning on Context-Dependent Domain Models.** S Böhme, T. Kühn. *Proceedings of the JIST (2017)*



### Design a role-based modeling language for RoSI

- ▶ Incorporate **all** natures of roles and model constraints
- ▶ Develop a *graphical* role-based modeling language
- ▶ Provide a *formal foundation* for the modeling language
- ▶ Offer readily *applicable tools* for modeling and code generation
- ▶ Support both *formal* and *automatic verification* of role models

# The Compartment Role Object Model (CROM)

## Graphical Notation

### Entities

Data Types

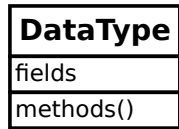

Natural Types

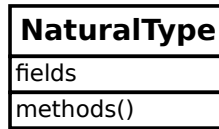

Compartment Types

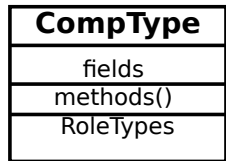

Role Types

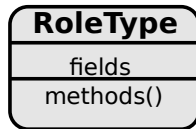

### Relations

Participation (participates-Relation)

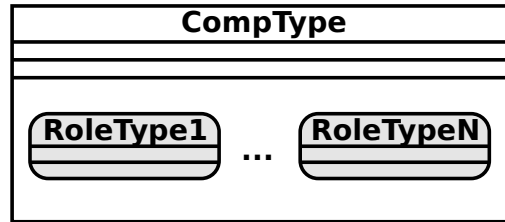

Rigid Type Inheritance

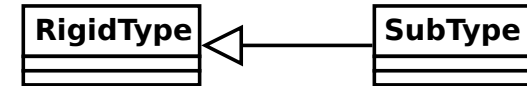

Binary Relationship

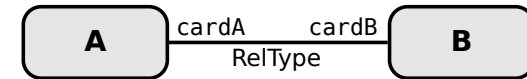

Fulfilment (fills-Relation)

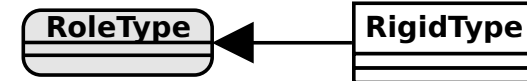

### Local Role Constraints

Role Groups

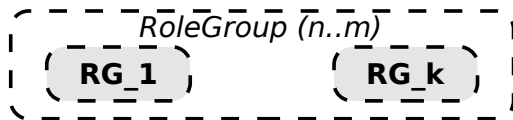

Role Constraints

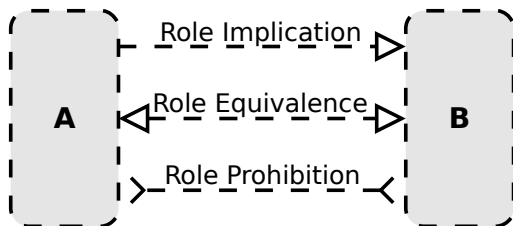

Occurrence Constraints



### Relationship Constraints

Intra-Relationship Constraints

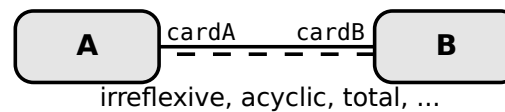

Inter-Relationship Constraints

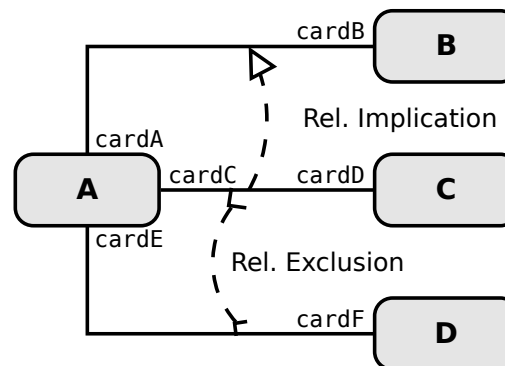

### Global Role Constraints

Universal    Existential    Relevant

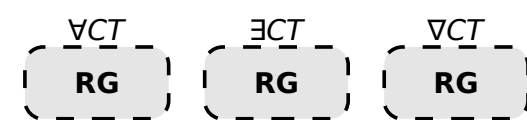

Global Implications / Prohibition

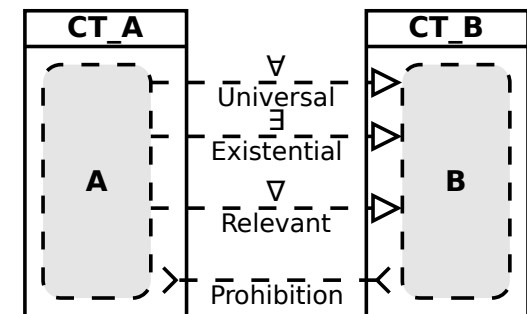

card = (n...m)  
where n is lower and m upper bound

# The Compartment Role Object Model (CROM)

## Graphical Notation

### Example: Banking Application

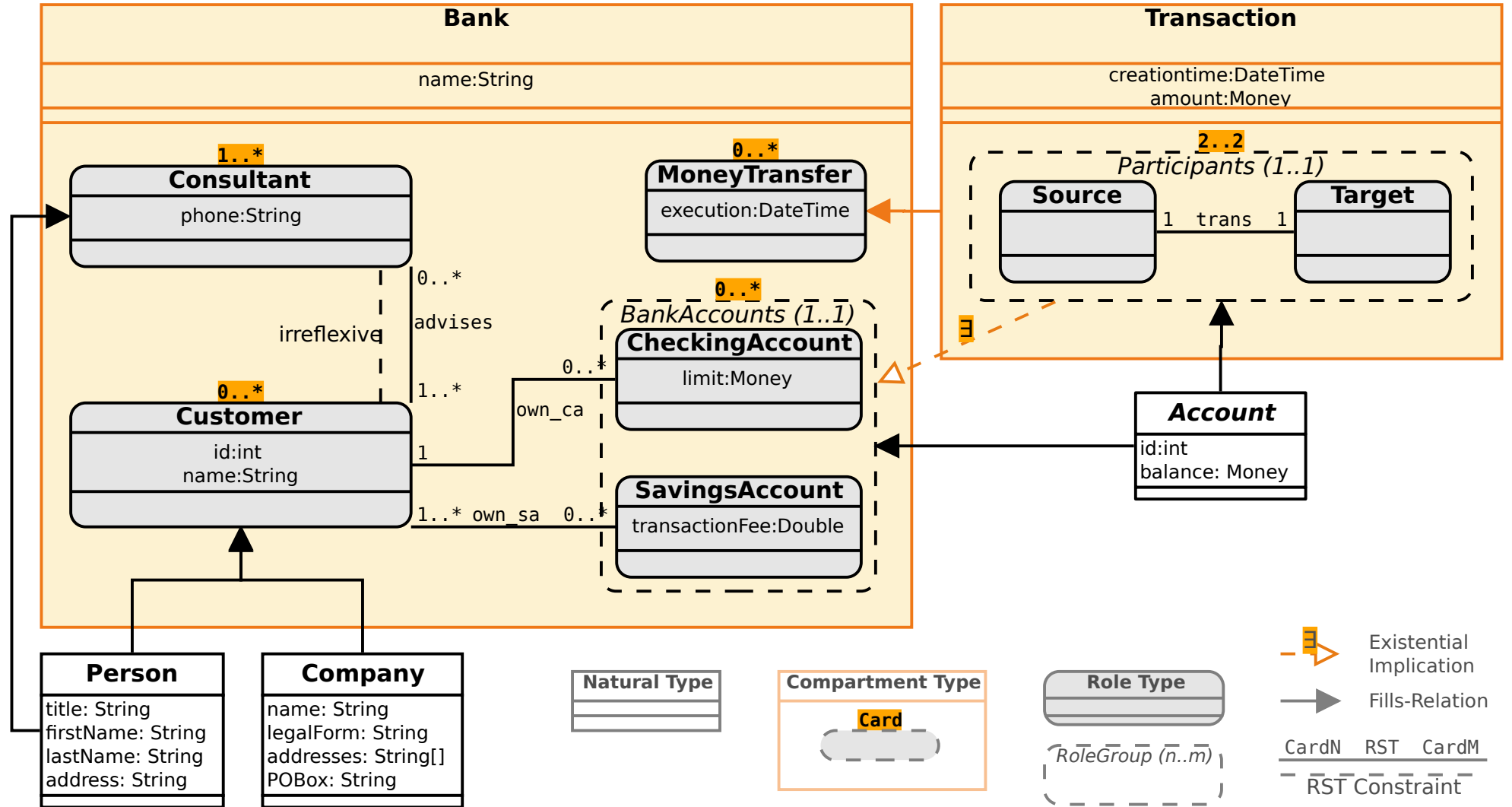

# The Compartment Role Object Model (CROM)

## Graphical Notation

### Context

- ▶ Prescriptive (Bottom Up)
- ▶ Have (so far) no identity
- ▶ Have no intrinsic behavior
- ▶ Indefinite lifetime
- ▶ Can not play roles
- ▶ Has no existential part

### Compartments

- ▶ Descriptive (Top Down)
- ▶ Instances carry identity (*Feature 26*)
- ▶ Have behavior and state (*Feature 19*)
- ▶ Have a defined lifetime
- ▶ Can play roles
- ▶ Has roles as parts (*Feature 20*)

### Compartment Types

- ▶ Denote an *objectified collaboration* between participants
- ▶ Declare a class of compartments (instances) with
  - Properties, behavior, role types, and relationships
- ▶ Represent *processes, teams, institutions, or “context”* [Kühn2014]

# The Compartment Role Object Model (CROM)

## Formal Foundation

### Ontological Foundation

Distinction of concepts by meta-properties:

- ▶ **Rigidity** [Steimann2000, Guizzardi2005]
  - Type is *rigid*, if its instances have this type until they die
- ▶ **Foundedness (Dependence)** [Steimann2000, Guizzardi2005]
  - Type is *founded*, if its instances depend on existence of other instances
- ▶ **Identity** [Guizzardi2005]
  - Whether identity of an instance is *unique*, *derived* or *composed* from others

Concept	Rigid	Founded	Identity	Example
Natural Types	yes	no	unique	<i>Person, Company</i>
Data Types	yes	no	derived	<i>Money</i>
Role Types	no <sup>1</sup>	yes	derived	<i>Consultant, Customer</i>
Compartment Types	yes	yes	unique	<i>Bank, Transaction</i>
Relationship Types	yes	yes	composite	<i>advises, owns</i>

<sup>1</sup>) Actual classified as **anti-rigid** by Guizzardi et.al. [Guizzardi2005]

### Ontological Foundation

Questions to classify domain concepts:

- ▶ **Rigidity**
  - Belong instances of the concept to this type throughout their lifetime?
- ▶ **Foundedness (*Dependence*)**
  - *Depend instances of the concept on existence of another instance?*
- ▶ **Identity**
  - *Carry instances of the concept a unique, derived or composite identity criterion?*

**Answers are still domain-dependent**

# The Compartment Role Object Model (CROM)

## Formal Foundation

### CROM EMOF (Ecore) Metamodel<sup>2</sup>

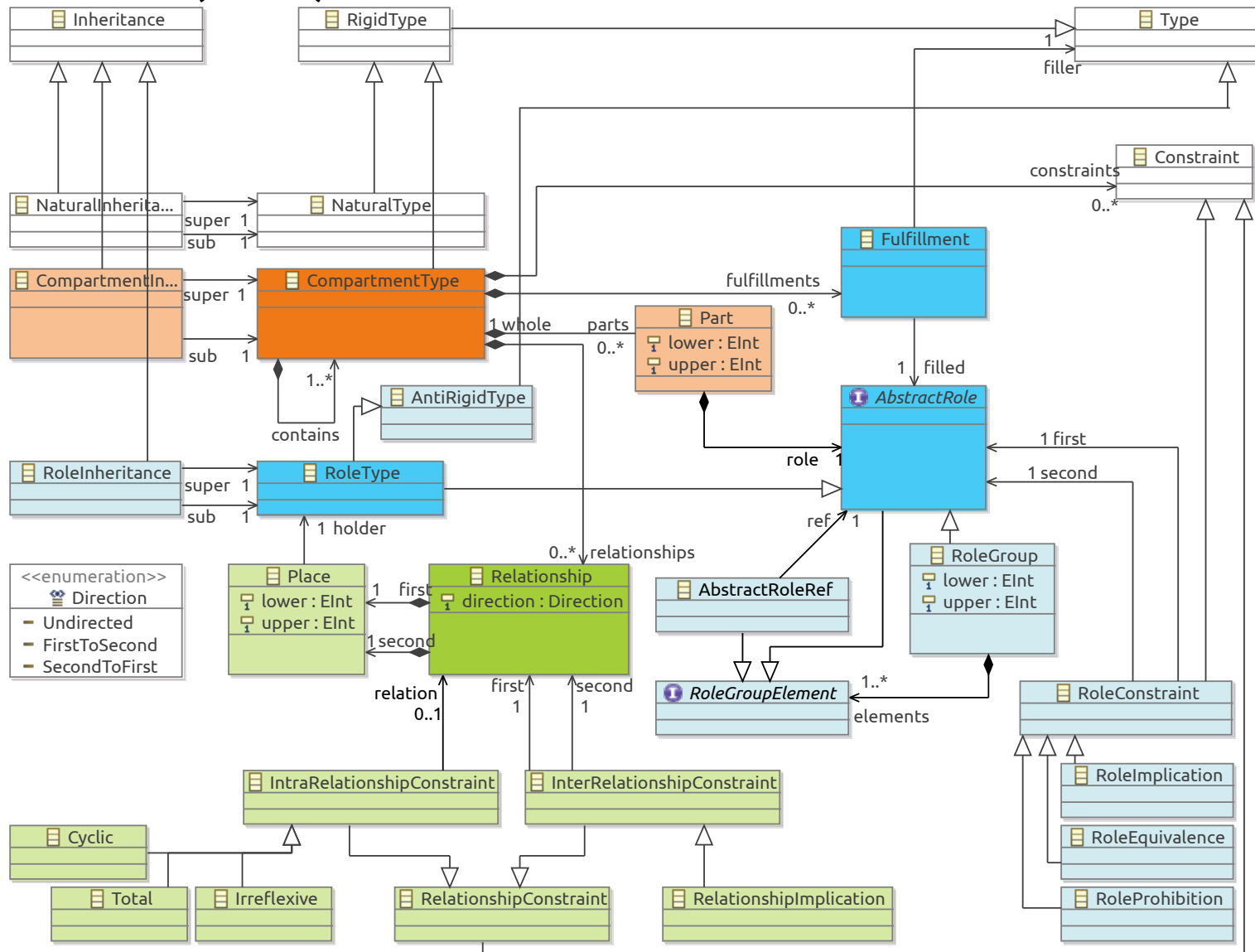

2) <https://github.com/Eden-06/CROM>



### Formal Model

#### Definition (Compartment Role Object Model)

$\mathcal{M} = (NT, RT, CT, RST, \text{fills}, \text{parts}, \text{rel})$  is a Compartment Role Object Model (CROM) with:

- $NT, RT, CT,$  and  $RST$  are mutual disjoint sets
- $\text{fills} \subseteq T \times CT \times RT$  is a relation (with  $T := NT \cup CT$ ) and
- $\text{rel} : RST \times CT \rightarrow (RT \times RT)$  is a partial function.

#### Definition (Compartment Role Object Instance)

$i = (N, R, C, \text{type}, \text{plays}, \text{links})$  is a Compartment Role Object Instance (CROI) of a well-formed CROM  $\mathcal{M}$  with:

- $N, R,$  and  $C$  are mutual disjoint sets
- $\text{type} : (N \rightarrow NT) \cup (R \rightarrow RT) \cup (C \rightarrow CT)$  is a labeling function,
- $\text{plays} \subseteq O \times C \times R$  a relation (with  $O := N \cup C$ ), and
- $\text{links} : RST \times C \rightarrow 2^{R \times R}$  is a total function.



### Constraint Model

#### Definition (Constraint Model)

$\mathcal{C} = (\text{rolec}, \text{card}, \text{intra}, \text{inter}, \text{grolec})$  is a Constraint Model over  $\mathcal{M}$  with:<sup>1</sup>

- $\text{rolec}: CT \rightarrow 2^{\text{Card} \times RG}$ , and
- $\text{card}: RST \times CT \rightarrow (\text{Card} \times \text{Card})$  are partial functions, as well as
- $\text{intra} \subseteq RST \times CT \times \mathbb{E}$  and
- $\text{inter} \subseteq RST \times CT \times IRC \times RST$  (with  $IRC := \{\triangleleft, \otimes\}$ ) are relations.
- Additionally,  $\text{grolec} \subseteq QRG$  is a finite set of quantified role groups.

#### Definition (Syntax of Role Groups)

Role Groups  $RG$  are defined inductively over  $RT$ :

$$\frac{rt \in RT}{rt \in RG} \qquad \frac{B \subseteq RG \quad n..m \in \text{Card}}{(B, n..m) \in RG}$$

#### Definition (Syntax of Quantified Role Groups)

Quantified Role Groups  $QRG$  are defined inductively over  $RT$ ,  $CT$  and  $RG$ :

$$\frac{a \in RG \quad ct \in CT \quad n..m \in \text{Card}}{\mathbb{Q}\langle ct, n..m \rangle.a \in QRG} \qquad \frac{B \subseteq QRG \quad n..m \in \text{Card}}{\langle B, n..m \rangle \in QRG}$$

<sup>1</sup> $\mathbb{E}$  is the set of functions  $e: 2^O \times 2^O \times 2^{O \times O} \rightarrow \{0, 1\}$ .

# The Compartment Role Object Model (CROM)

## Tool Support

42

Model-Driven Software Development in Technical Spaces (MOST)

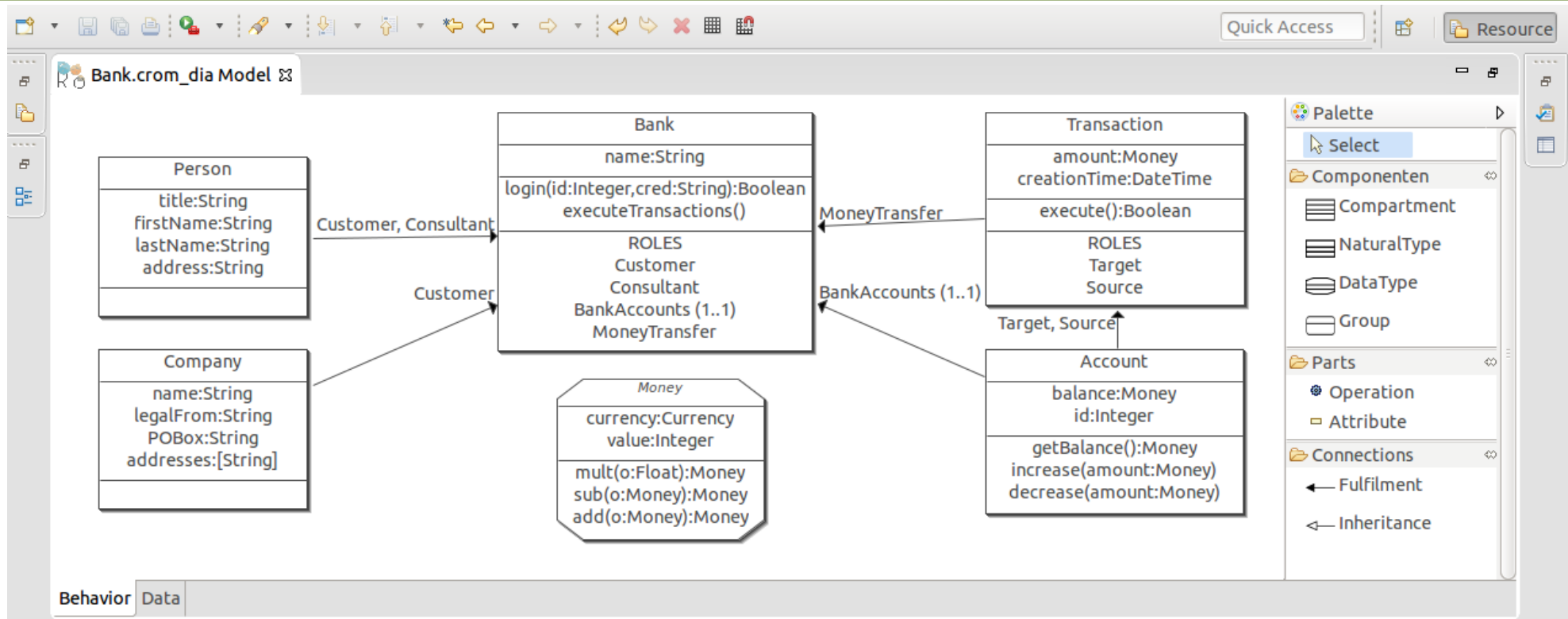

## Full-fledged Role Modeling Editor (FRaMED)<sup>3</sup>

- ▶ Zoomable editor with Top-Level and Focus view for *Compartment Types*
- ▶ Top-Level view for specifying:
  - Natural, *Data* and *Compartment Types*, as well as *inheritance* and *fulfillment*
- ▶ Focus view for specifying
  - *Role* and *Relationship Type*, as well as *Role Groups* and *Constraints*

3) <https://github.com/leondart/FRaMED>

# The Compartment Role Object Model (CROM)

## Tool Support

43

Model-Driven Software Development in Technical Spaces (MOST)

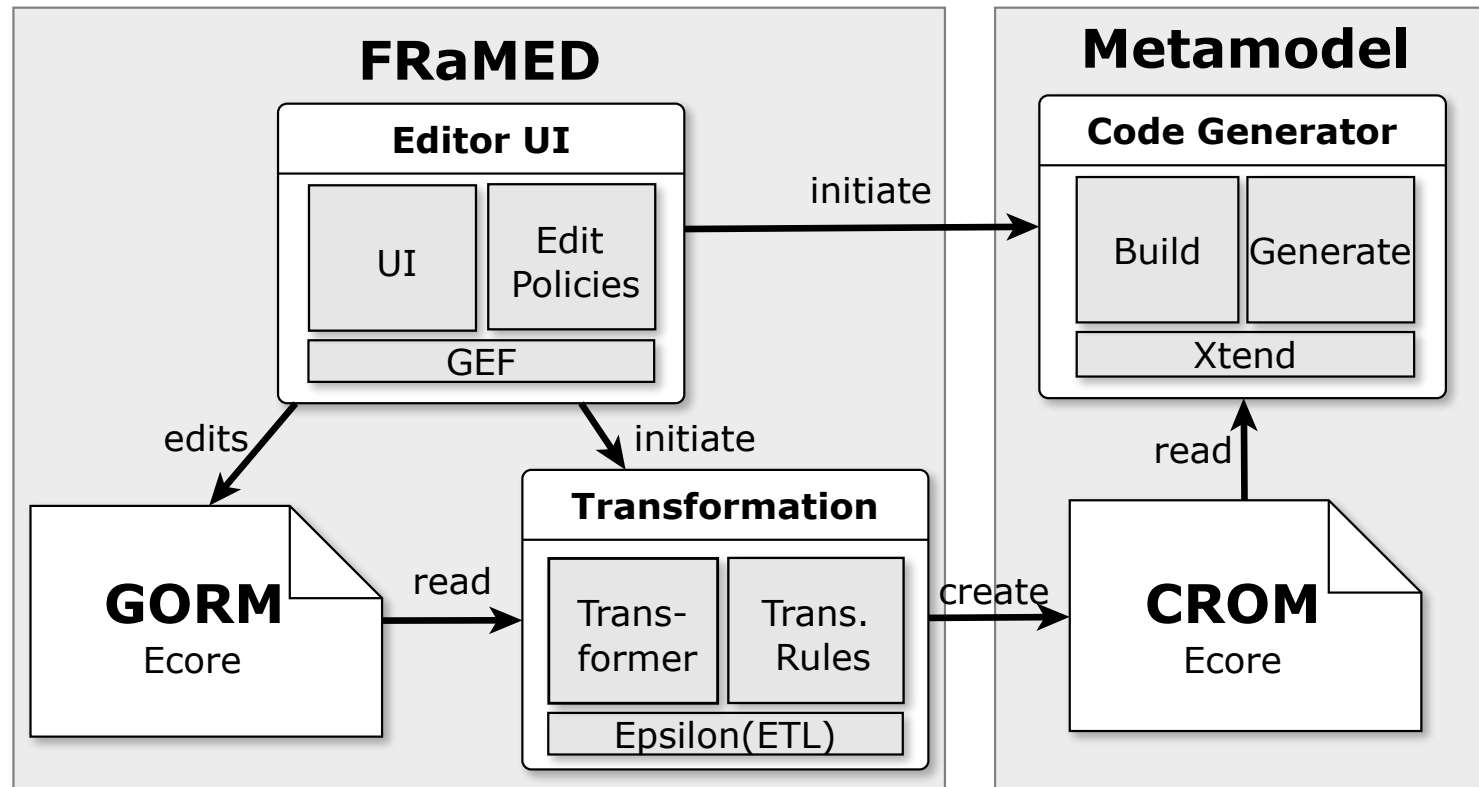

### Full-fledged Role Modeling Editor (FRaMED)<sup>3</sup>

- ▶ Fully model-driven Eclipse-based editor based on:
  - *Eclipse Modeling Framework (EMF), Graphical Editing Framework (GEF), Epsilon (ETL)*
- ▶ Separation of *Graphical Model (GORM)* and *Semantic Model (CROM)*

3) <https://github.com/leondart/FRaMED>

# The Compartment Role Object Model (CROM)

## Tool Support

44

Model-Driven Software Development in Technical Spaces (MOST)

### Additional tools supported by FRaMED

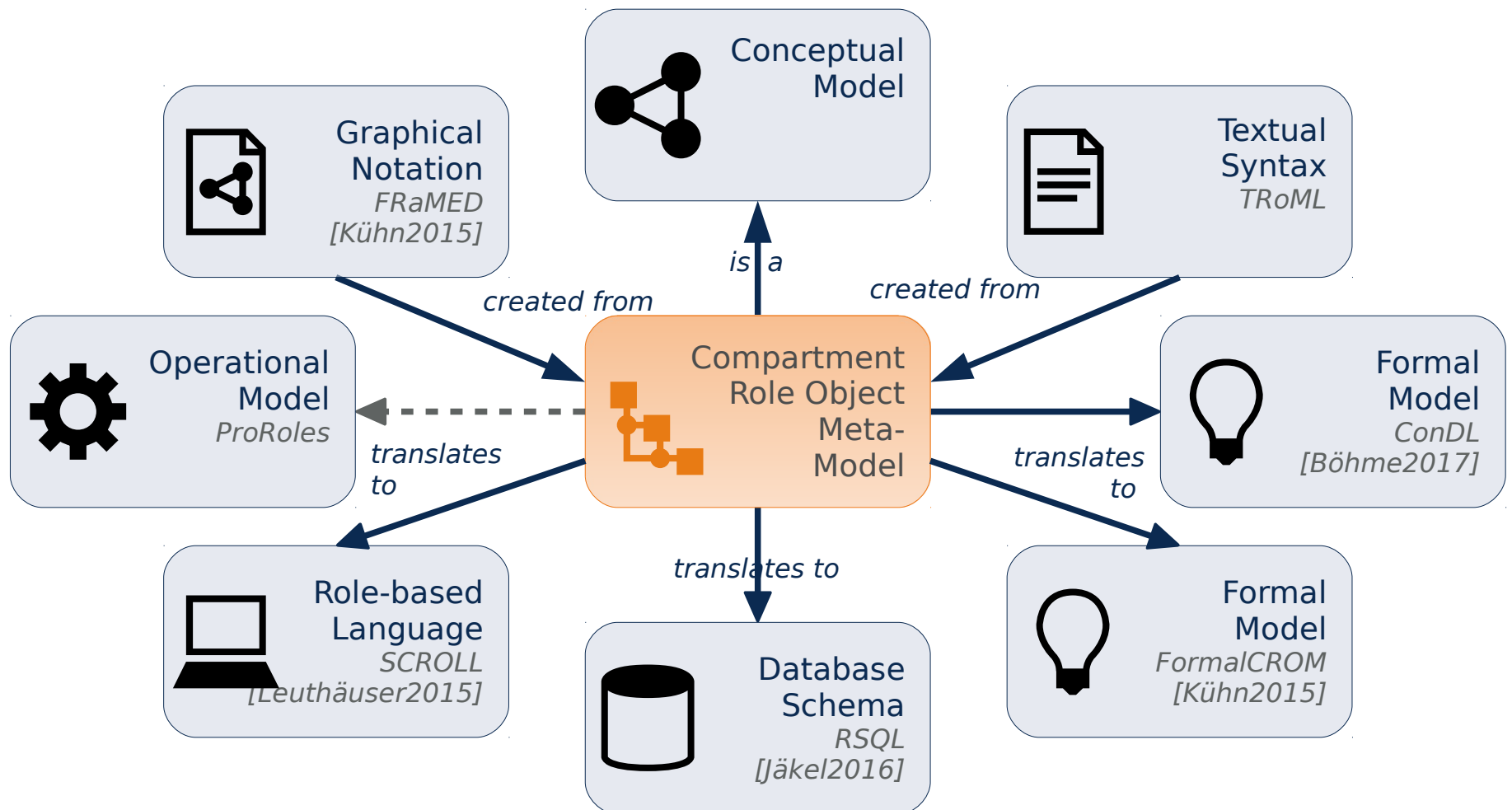

# The Compartment Role Object Model (CROM)

## Conclusion

- ▶ Incorporating **all** *natures of roles* and various *modeling constraints*
- ▶ Modeling language (formal CROM) fulfilled 22 (19) features of roles
- ▶ Introduce common *graphical notation* for role-based modeling languages
- ▶ CRO(meta-)Model provides its *abstract syntax*
- ▶ FRaMED as eclipse-based editor for *modeling* and *code generation*
- ▶ Propose *CROM* as formal foundation for roles

**Still no** common role-based modeling language  
supporting **all language variants**

# The End

- ▶ Why is it hard to unify the role concept?
- ▶ Why are compartments necessary to group roles in metamodels?
- ▶ What was crucial for providing tool support for RoSI?