

Prof. Dr. Frank J. Furrer
frank.j.furrer@bluewin.ch

Petri Nets for Modeling of **Large** Discrete Systems

The Reggie Davidrajuh Methodology





<https://st.inf.tu-dresden.de/teaching/hs>

<https://edoc.sub.uni-hamburg.de/informatik/volltexte/2011/160/>



K o m m u n i k a t i o n .
m i t
A u t o m a t e n

Von der Fakultät für Mathematik und Physik
der Technischen Hochschule Darmstadt

zur Erlangung des Grades eines
Doktors der Naturwissenschaften
(Dr. rer.nat.)

genehmigte
Dissertation

vorgelegt von

C a r l A d a m P e t r i

aus Leipzig

Referent: Prof.Dr.rer.techn.A.Walther

Korreferent: Prof.Dr.Ing.H.Unger

Tag der Einreichung: 27.7.1961

Tag der mündlichen Prüfung: 20.6.1962

D 17

Bonn 1962

Eingegangen am 27.7.1961

Anschrift des Verfassers: Institut für Angewandte Mathematik
der Universität Bonn, Wegelerstr. 10

Als Manuskript gedruckt im Mathematischen Institut der Universität
Bonn, Wegelerstr. 10

State of the Art of Petri Net Modeling:

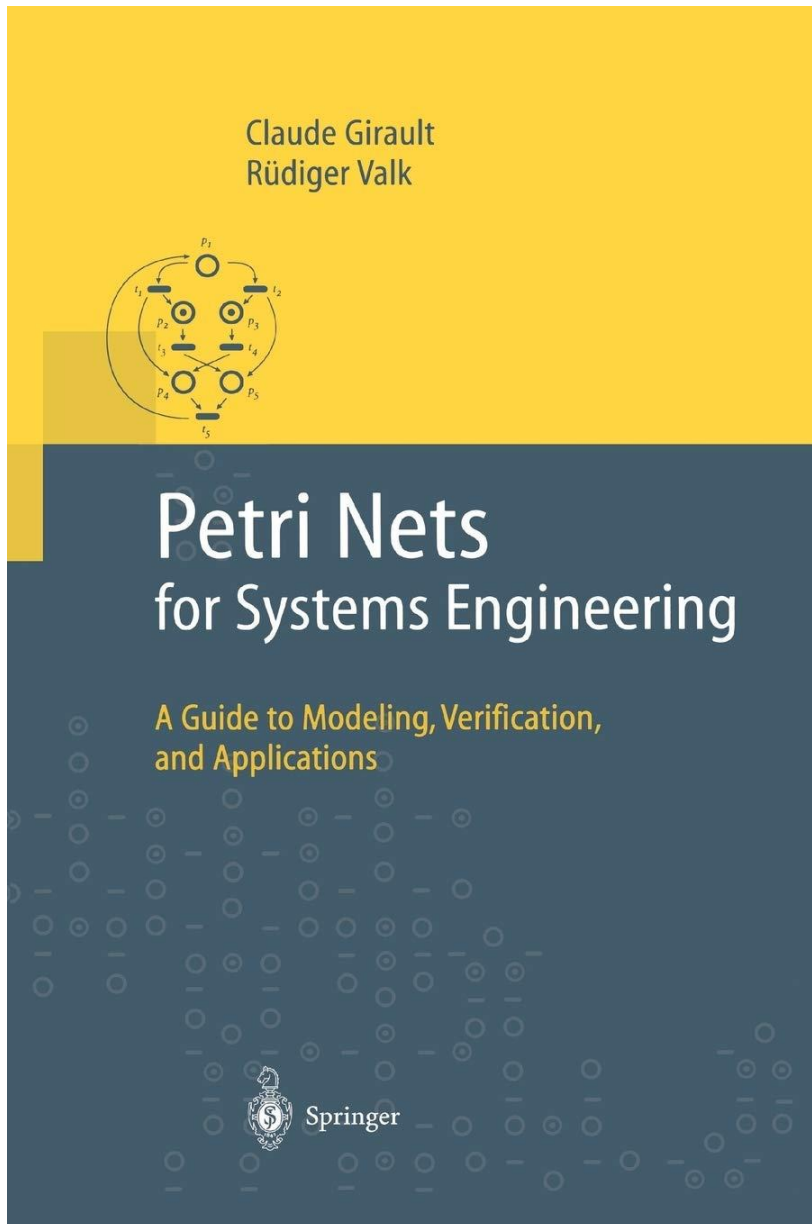

Claude Girault, Rüdiger Valk:

**Petri Nets For Systems Engineering:
*A Guide to Modeling, Verification, and Applications***

Springer Verlag, Berlin, 2003

ISBN-13 : 978-3-642-07447-9

Petri Net Varieties

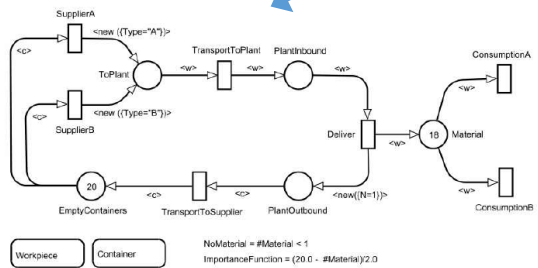
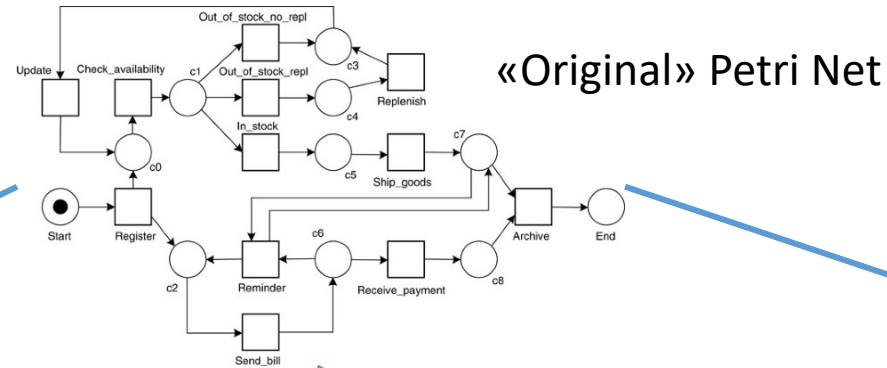

Stochastic colored Petri Net

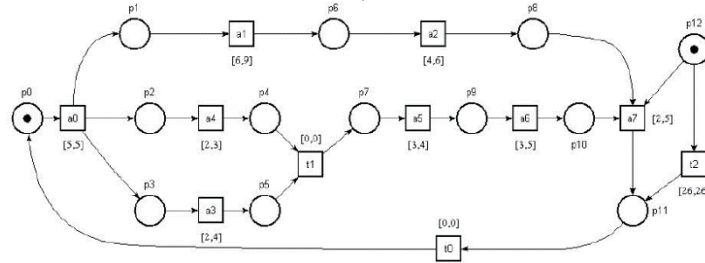

Timed Petri Net

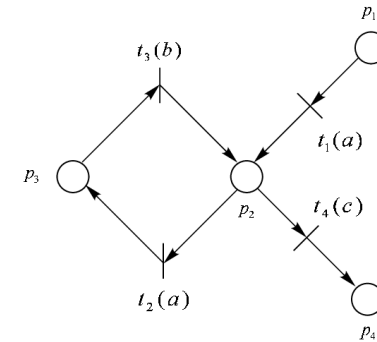

Labeled Petri Net

etc.

https://www.researchgate.net/figure/Stochastic-colored-Petri-net-model-of-a-supply-chain_fig1_228918128

https://www.researchgate.net/figure/Labeled-Petri-net-structure-for-Example-1_fig1_224560983

https://www.researchgate.net/figure/Time-Petri-Net-model-with-observer-to-check-property_fig4_228619768

State Space Explosion

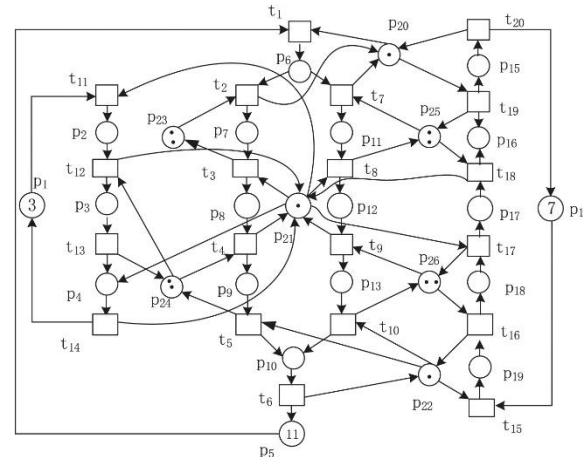

State Space Explosion

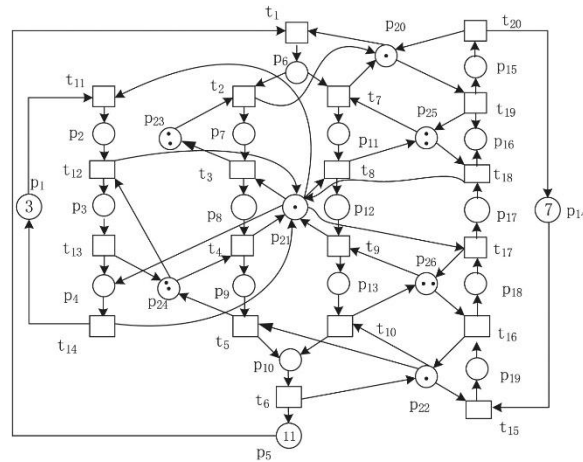

1

Functional Partitioning

- Modularization
- Complexity reduction
- Separation of concerns

Required:

2

Composition Method

- Assembly of Partitions
- Module interfacing
- **No hierarchy!**

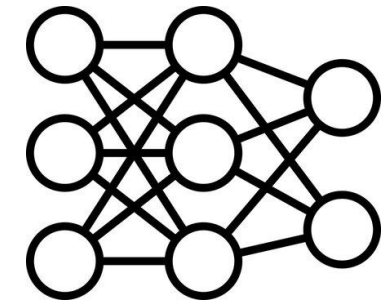
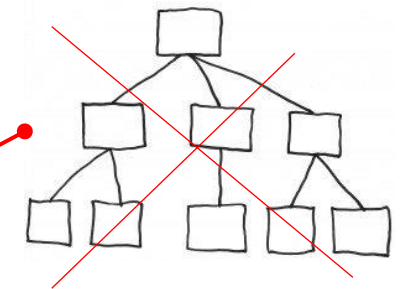

Network Modeling Freedom

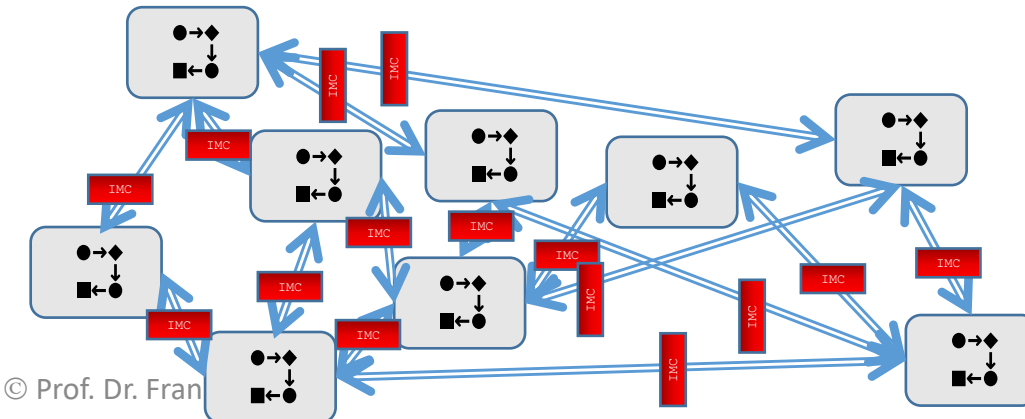
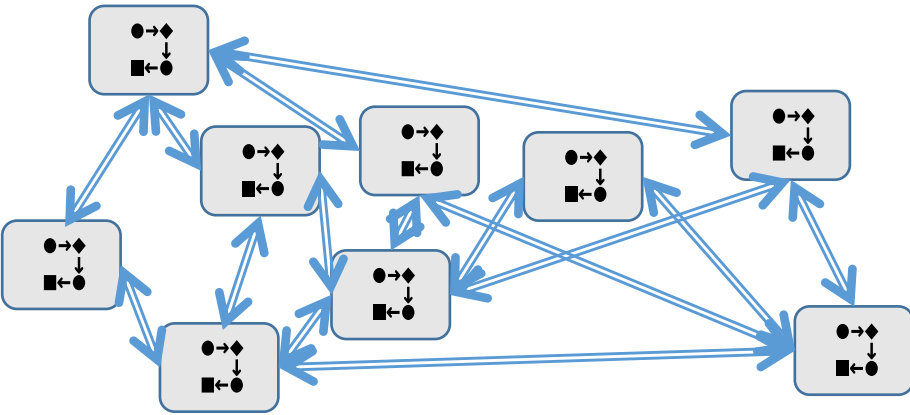

State Space Explosion

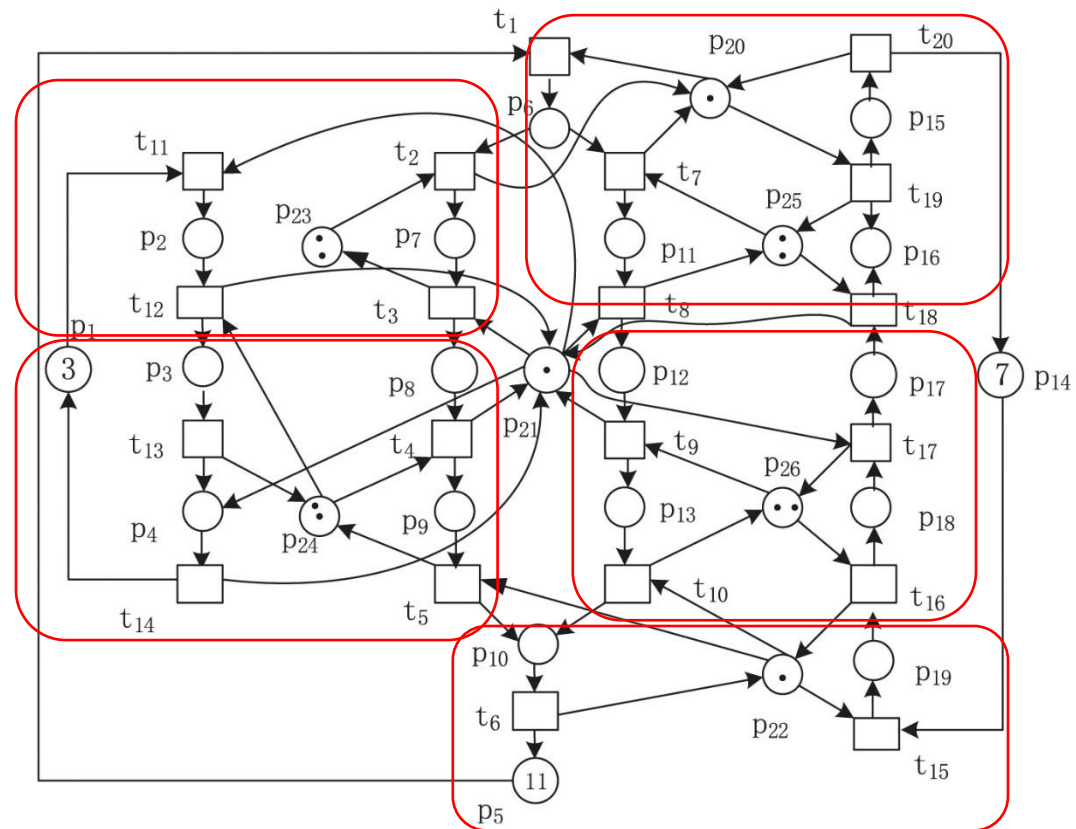
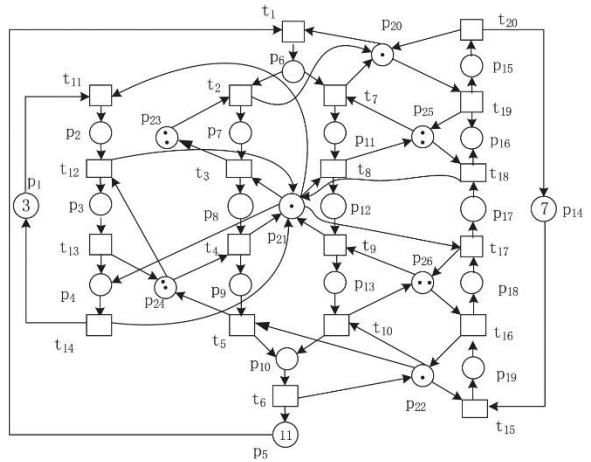

Suitable
Functional Partitioning
required

1

Composition

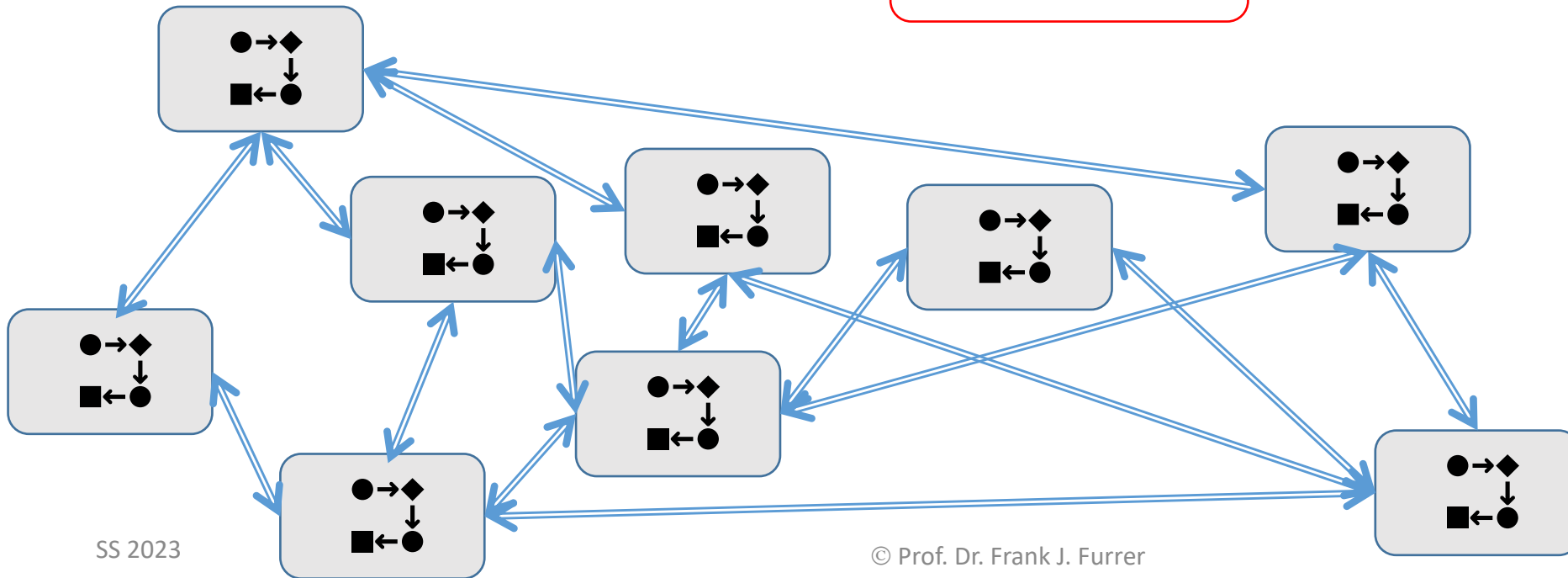
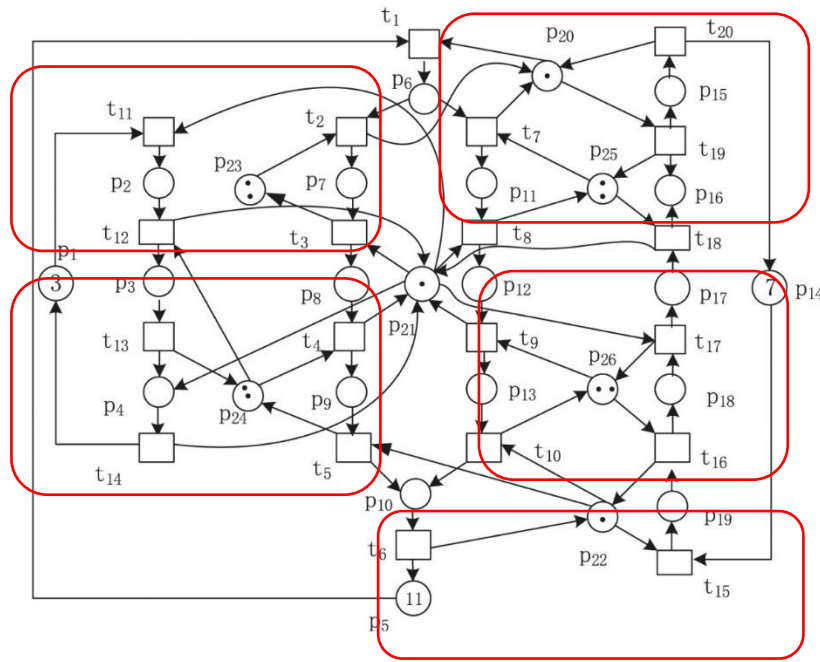

2

Suitable
**Composition
Method**
required

Reggie Davidrajuh:

Petri Nets for Modeling of Large Discrete Systems

Springer Nature Singapore Pte., Singapore, 2021

ISBN 978-9-811-65202-8

Asset Analytics
Performance and Safety Management
Series Editors: Ajit Kumar Verma · P. K. Kapur · Uday Kumar

Reggie Davidrajuh

Petri Nets for Modeling of Large Discrete Systems



Modular Petri Nets

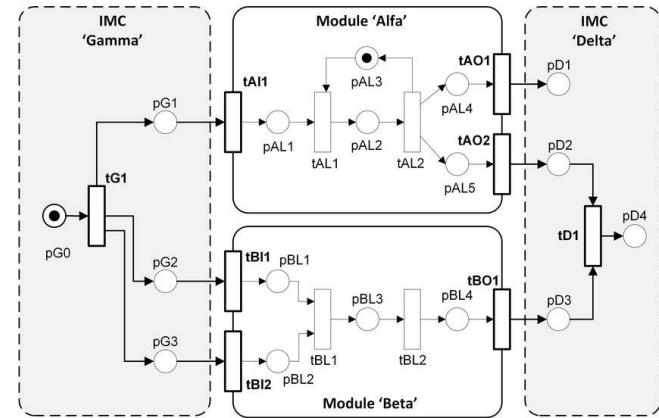

Petri Modules

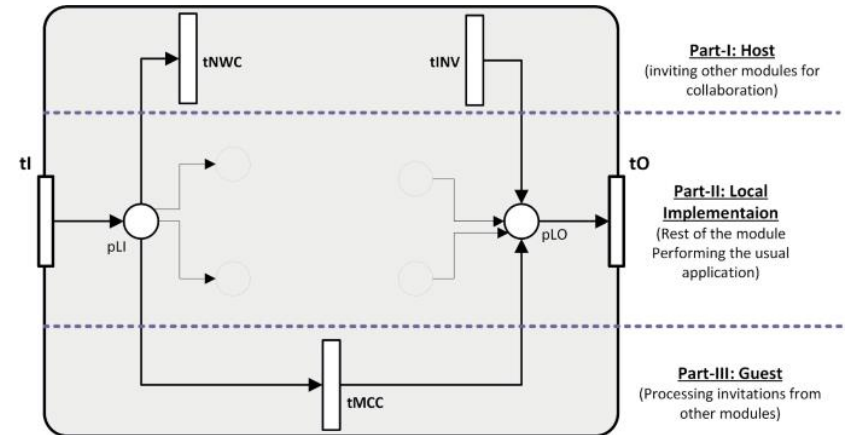

Petri Module: **Key Concepts**

2 Building Blocks of Modular Petri Nets

Inter-Modular Connector [IMC]

1 Petri Modules

Inter-Modular Connector [IMC]

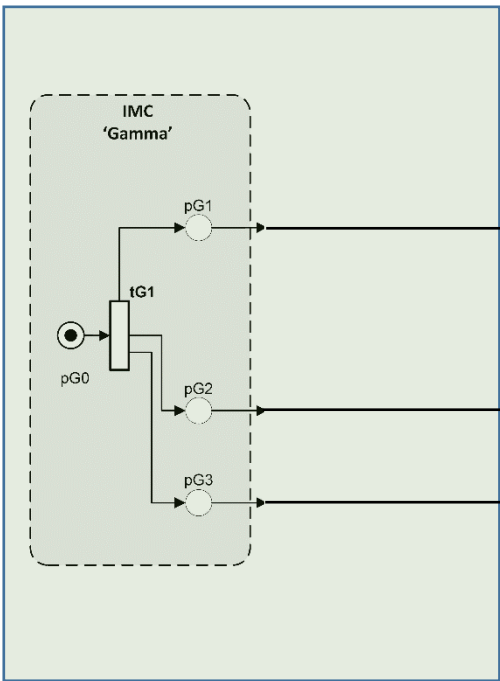

Input Port

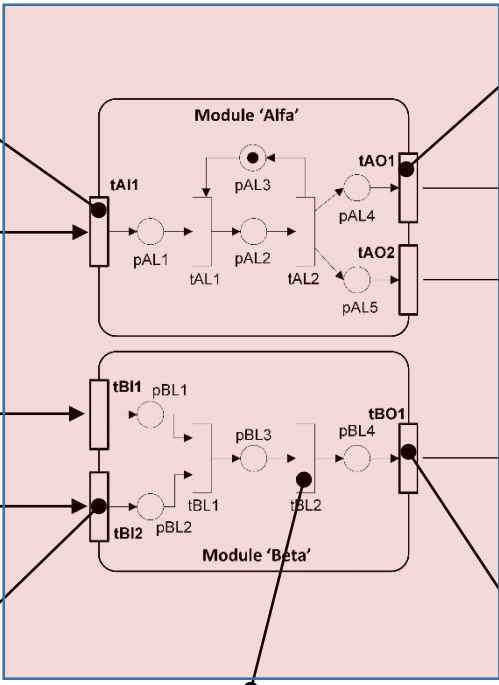

Output Port

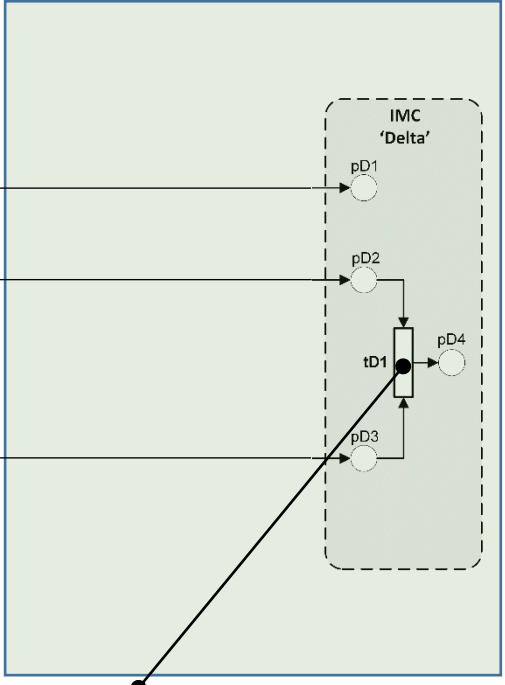

Transition 1:
Input Port Transition

Transition 2:
Local Transition

Transition 3:
Output Port Transition

Transition 4:
Inter-Modular Transition

Petri Module: **Key Concepts**

<https://www.mdpi.com/2073-431X/8/4/83>

A **Petri Module** is defined as a six-tuple:

$$\Phi = (P_{L\Phi}, T_{IP\Phi}, T_{L\Phi}, T_{OP\Phi}, A_{\Phi}, M_{\Phi 0}),$$

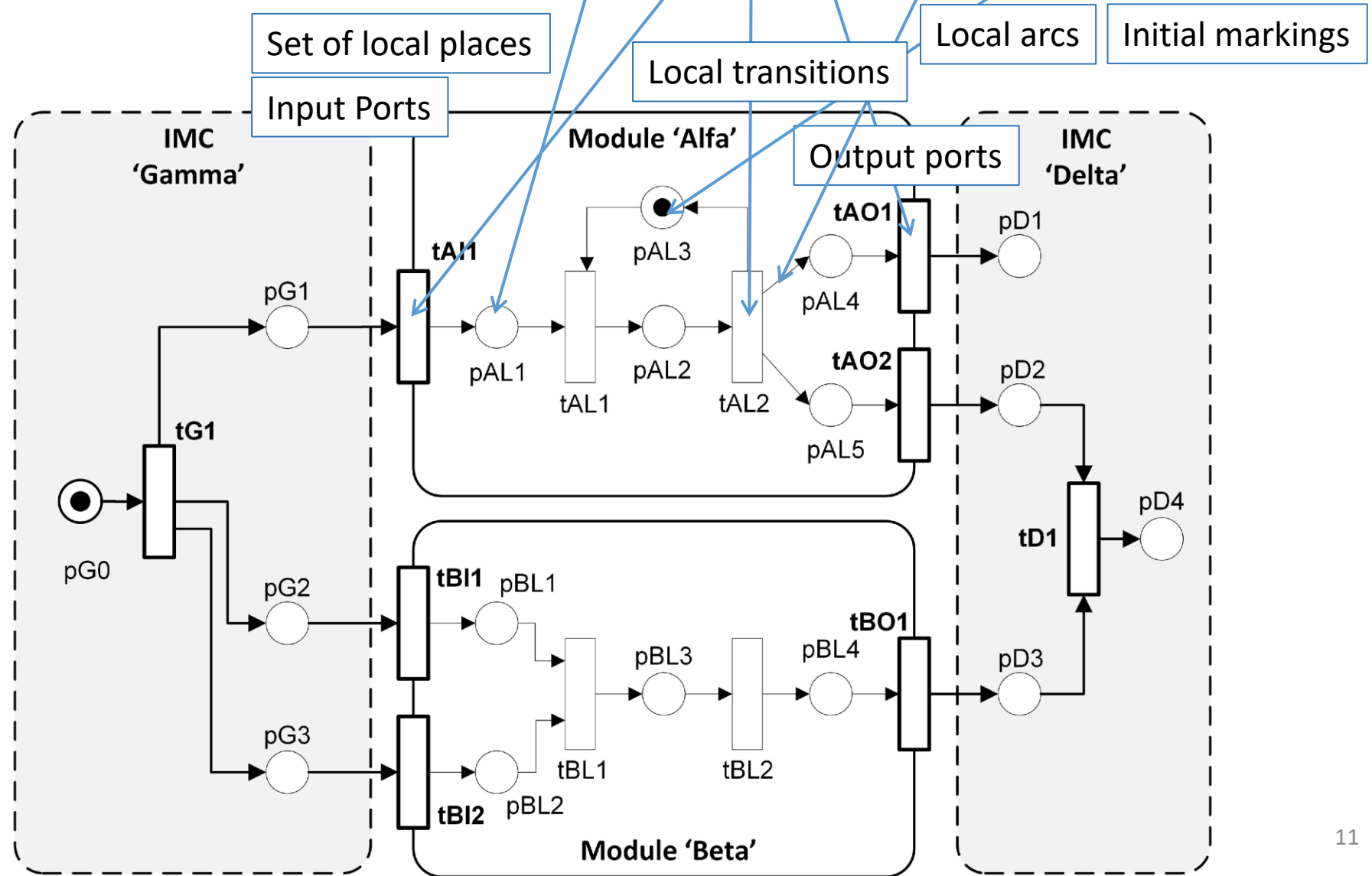

Petri Module: **Key Concepts**

<https://www.mdpi.com/2073-431X/8/4/83>

2 Building Blocks of Modular Petri Nets

2 Inter-Modular Connector [Composition]

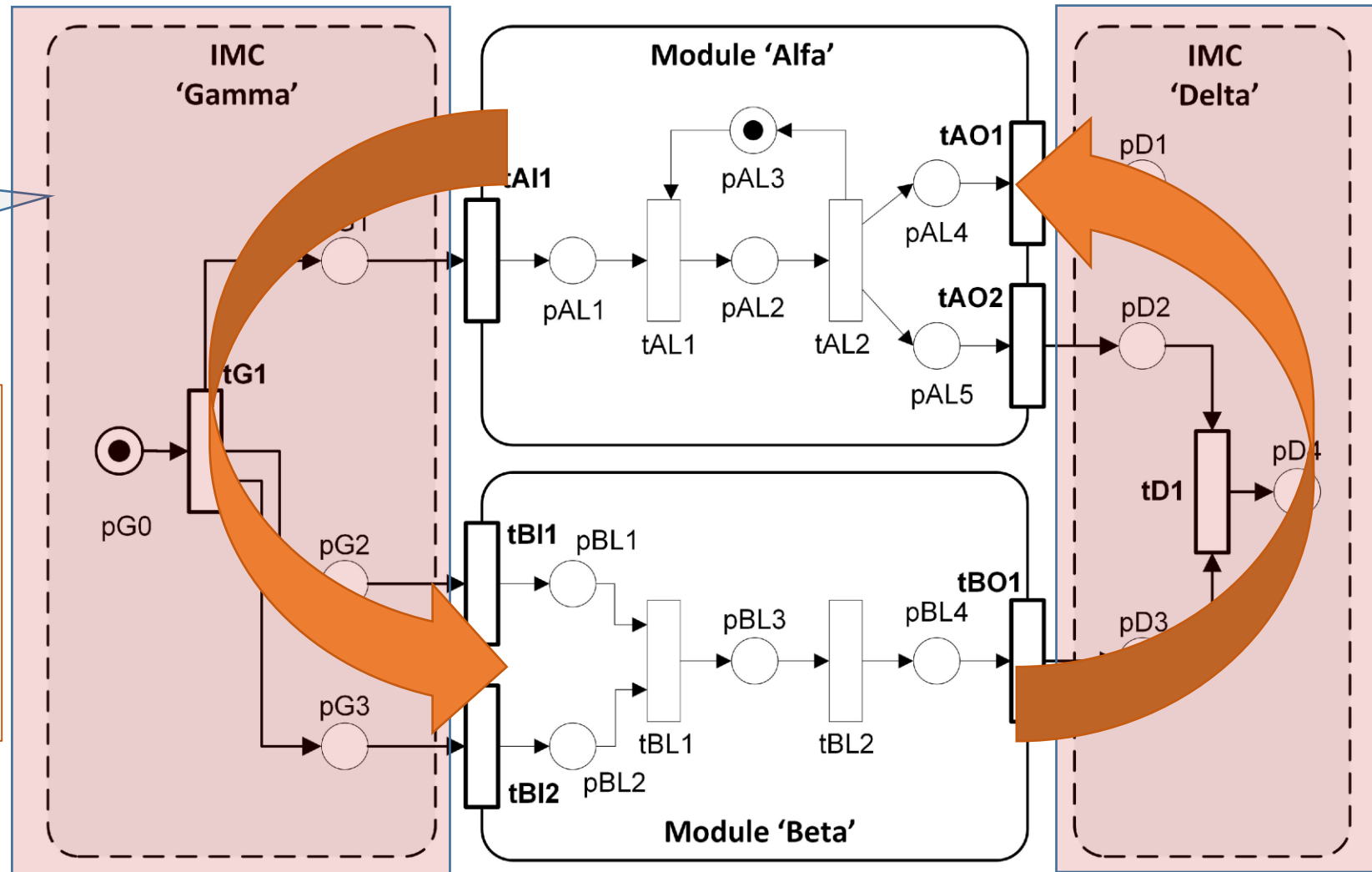

Inter-Modular Connector [IMC]

- Connecting/Composing Petri Modules:**
- Functionality
 - Control Flow
 - Timing
 - Mesh Structure
 - Same Formalism

Petri Module: **Key Concepts**

An **Inter-modular Connector (IMC)** is defined as a four-tuple:

$$\Psi = (\underbrace{P_\Psi}_{\text{Set of IMC places}}, \underbrace{T_\Psi}_{\text{IMC transitions}}, \underbrace{A_\Psi}_{\text{IMC arc}}, \underbrace{M_{\Psi_0}}_{\text{Initial markings}})$$

<https://www.mdpi.com/2073-431X/8/4/83>

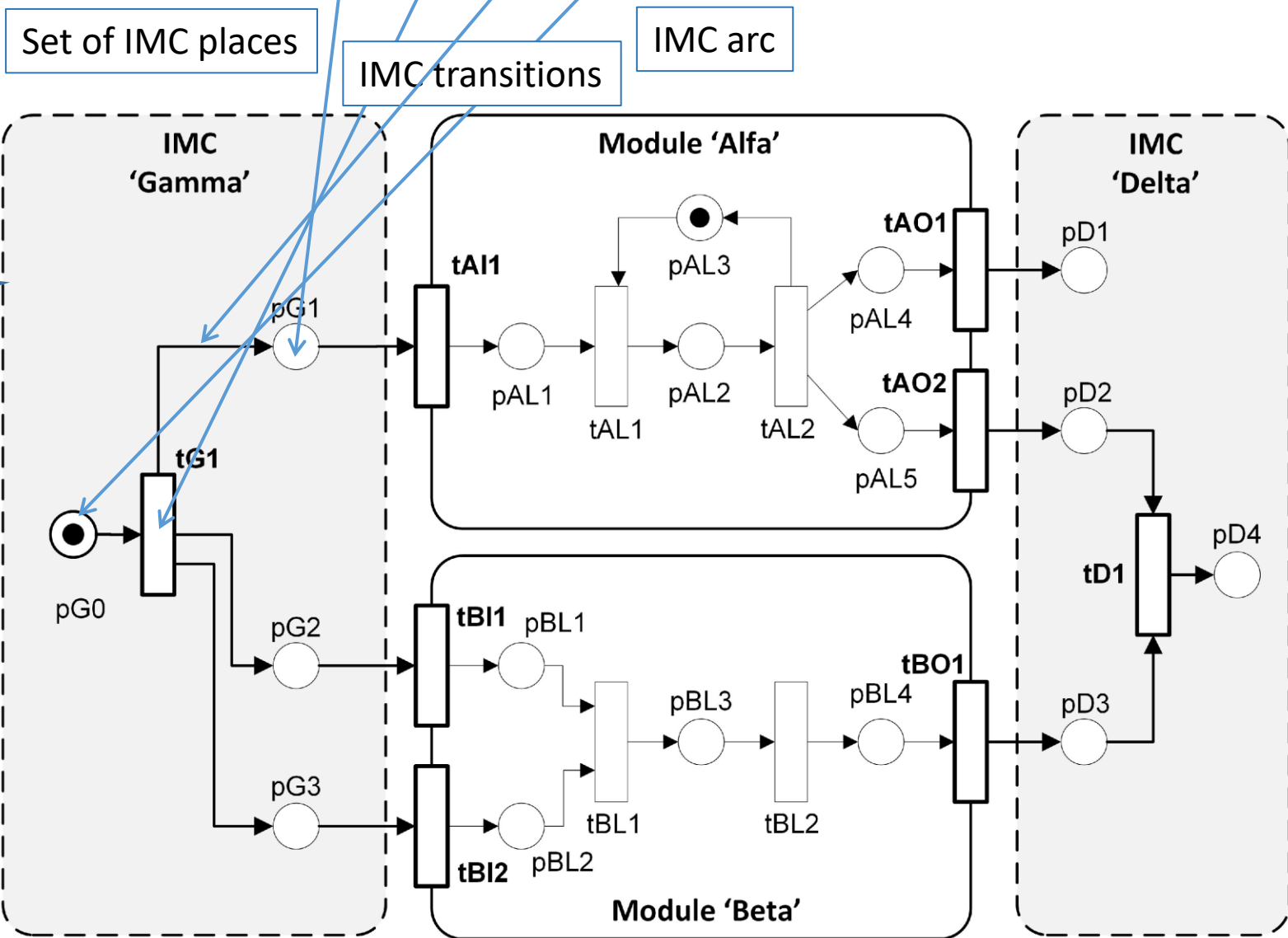

Inter-Modular Connector [IMC]

Composition

Composition Method:
Inter-Module Connector [IMC]

Composition Structure:
Network/Mesh [unrestricted]

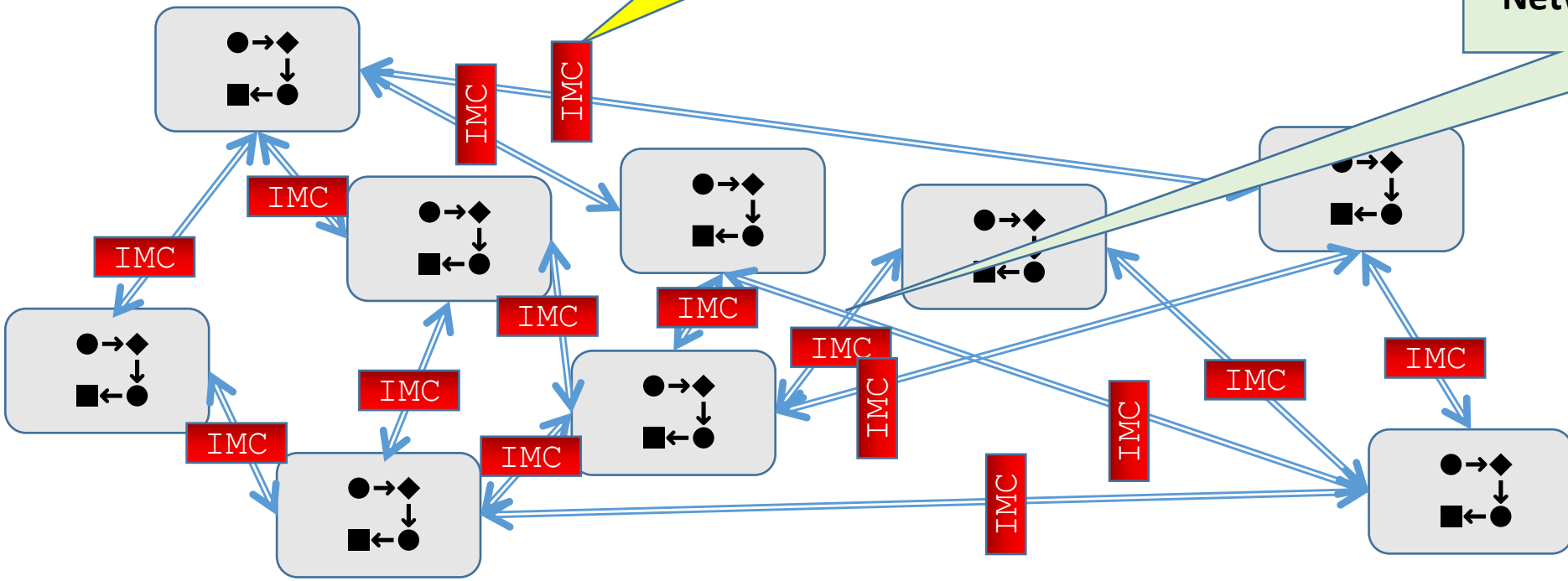

Modular Petri Net

A Modular Petri Net is defined as a two-tuple:

$$MPN = (M, \mathcal{C})$$

One or more Petri Modules

Zero or more Inter-Modular Connectors

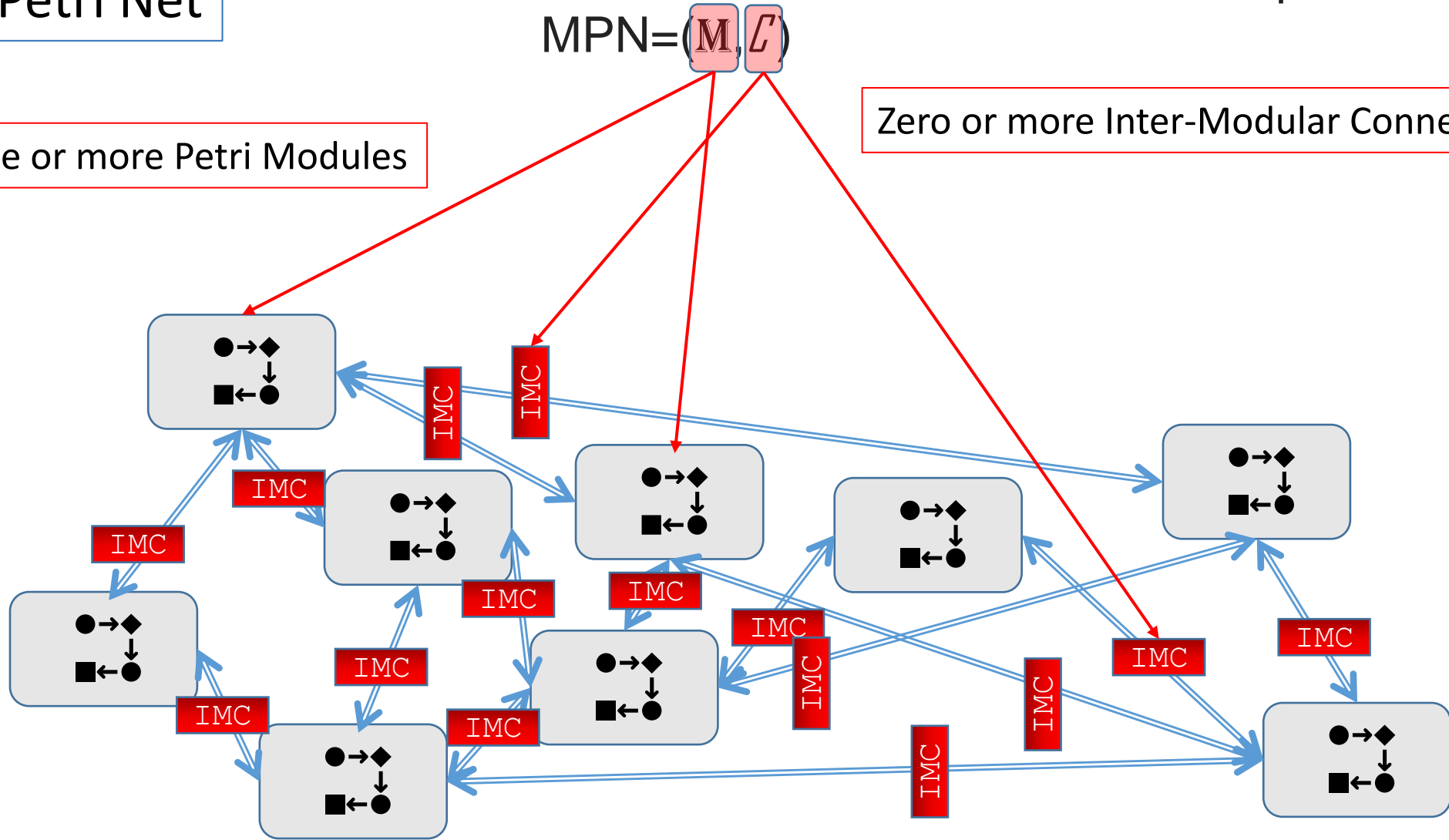

Modular Petri Net
= **Timed Petri Net**

Example:
Flexible Manufacturing System [FMS]

Functional Decomposition:
4 Modules Loosely Coupled

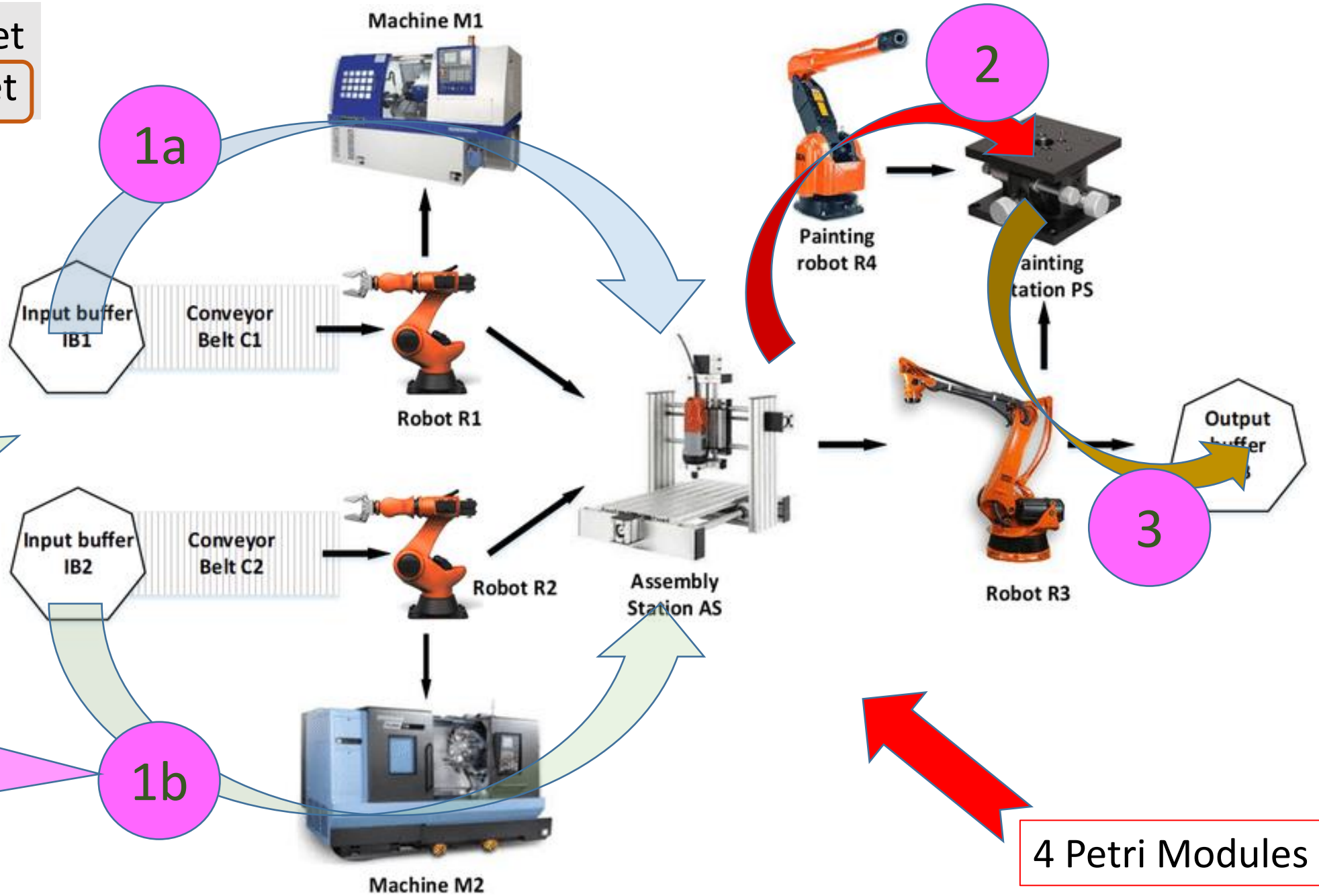

4 Petri Modules

Distributed Development & Deployment

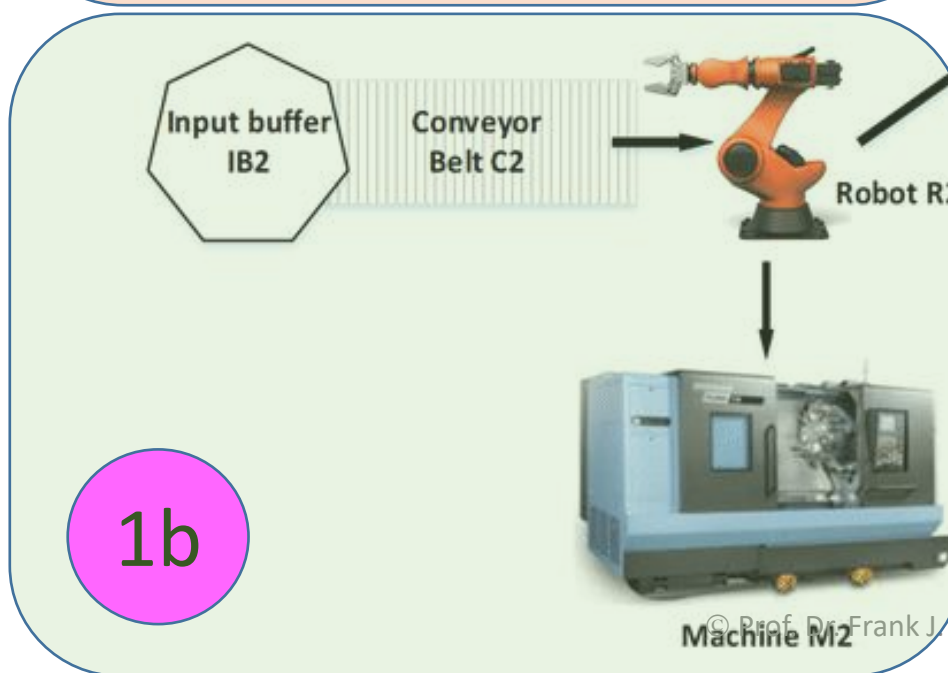
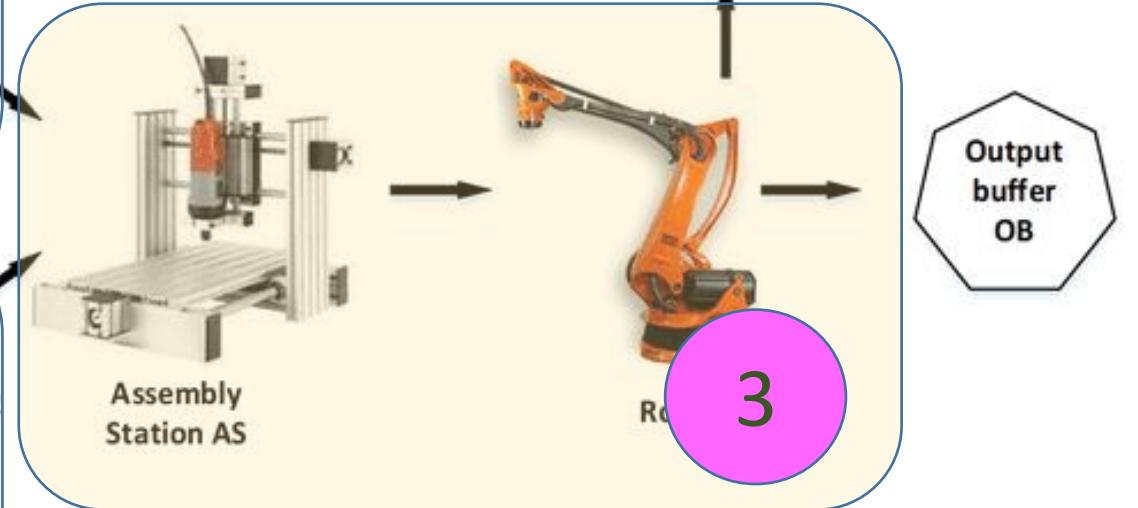
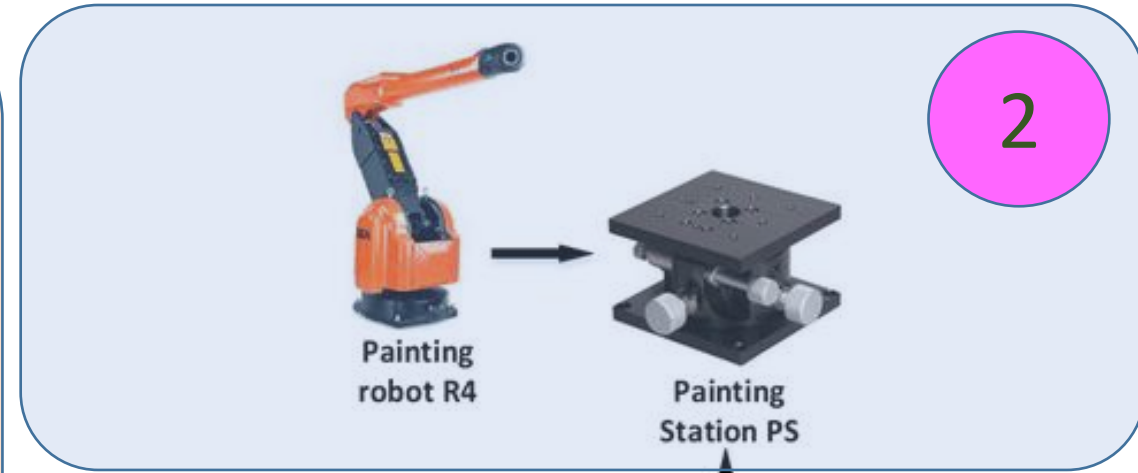
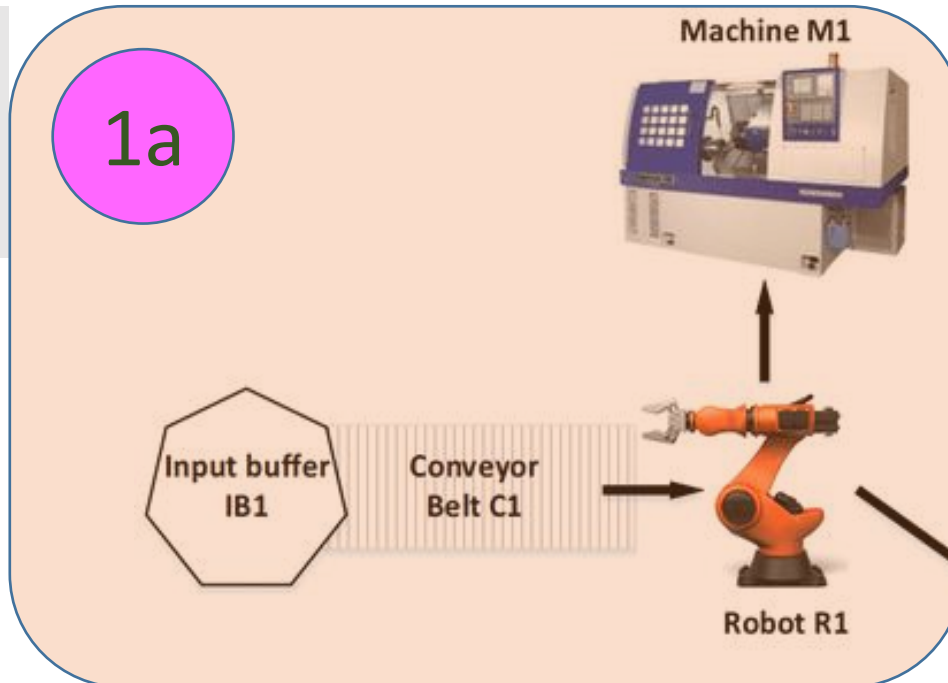

Modular Petri Net
= **Timed** Petri Net

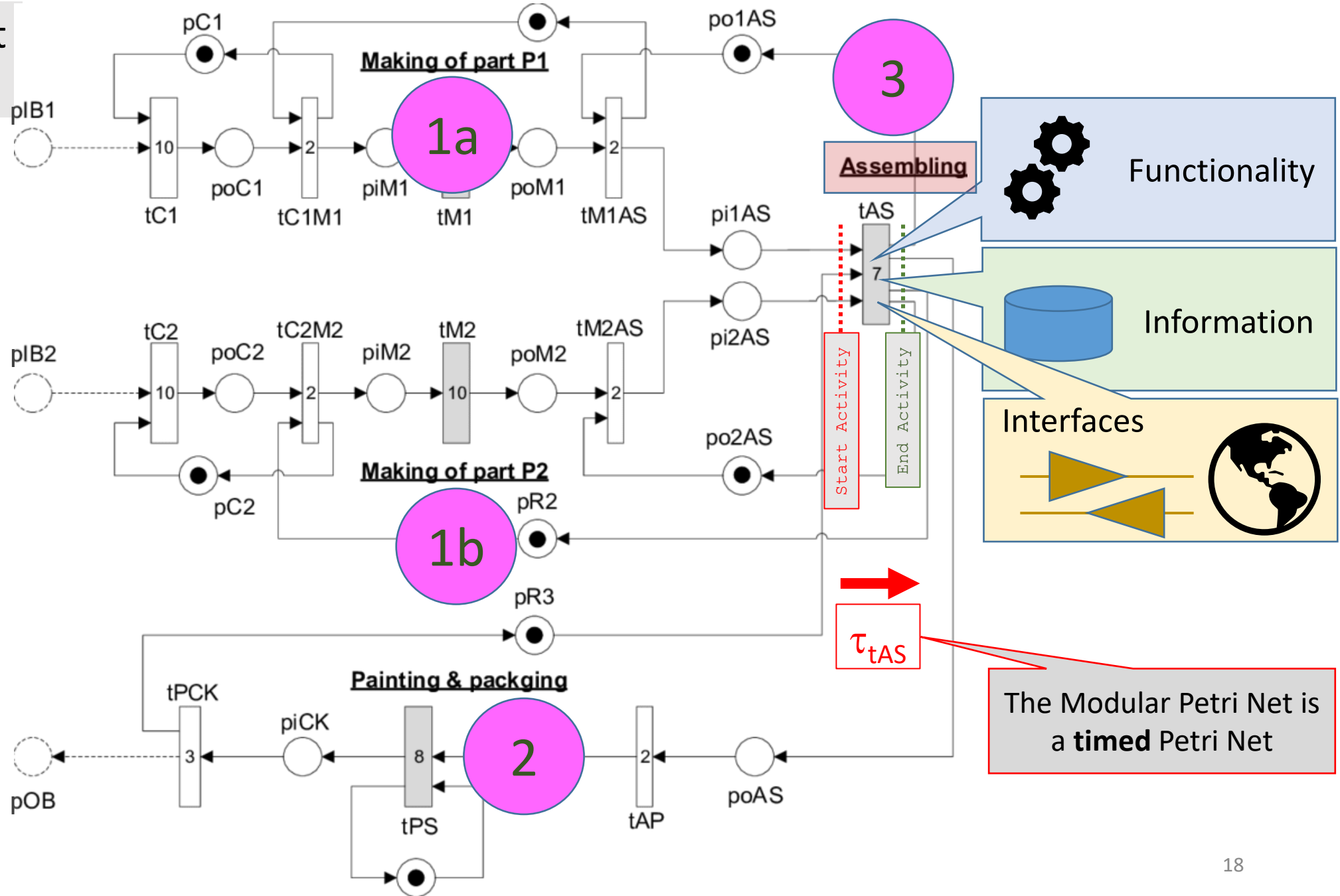

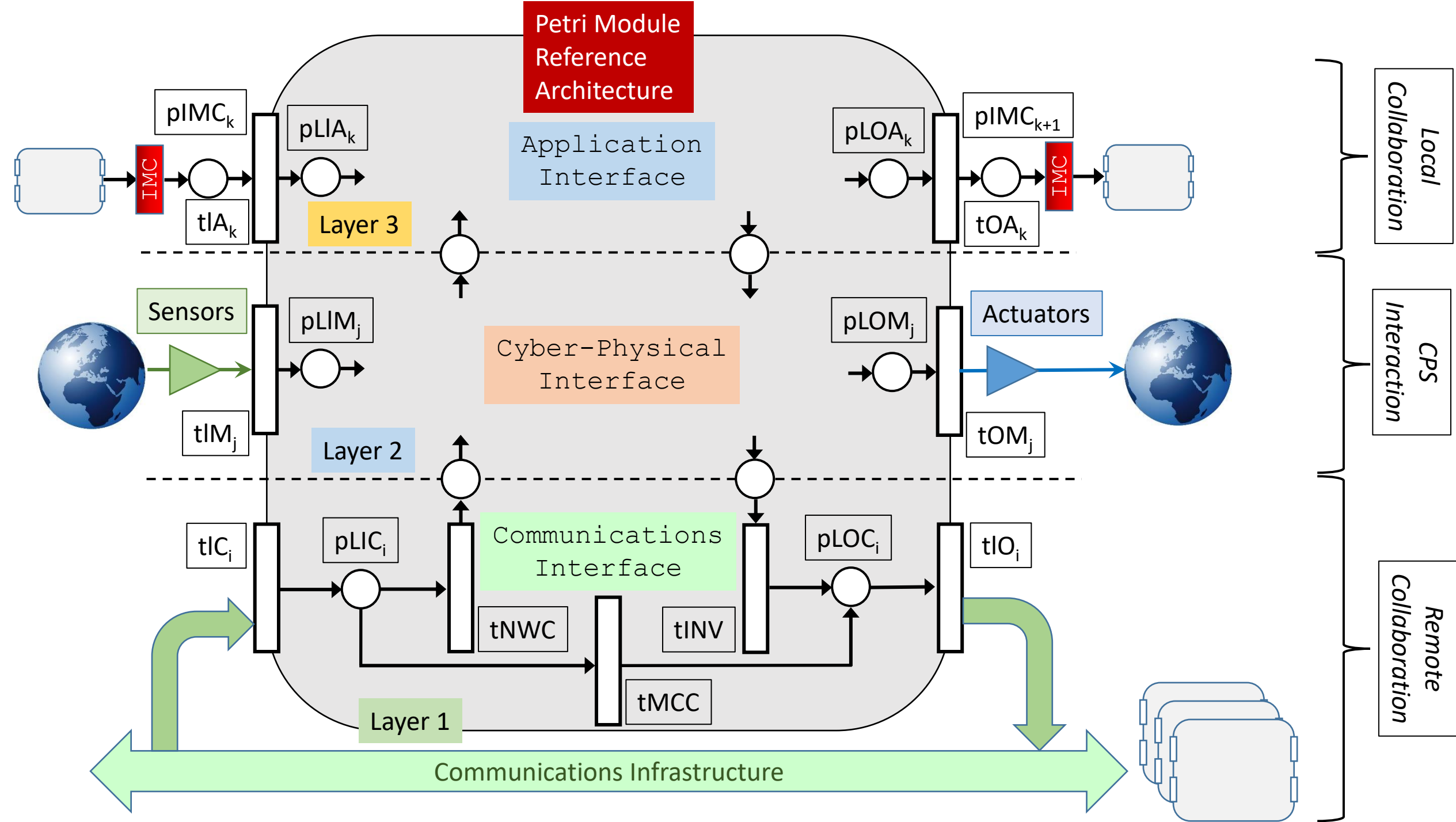

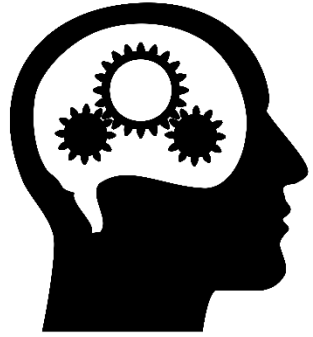

Modular Petri Net Engineering

2) Definition of the Relationships \Leftarrow Conceptual Model

1) Functional/Information **Partitioning** of the Information System (Modularization, Separation of Concerns) \Leftarrow **Conceptual Model**

\Rightarrow Specification of the Petri Modules

Specification of the Inter-Module Connectors

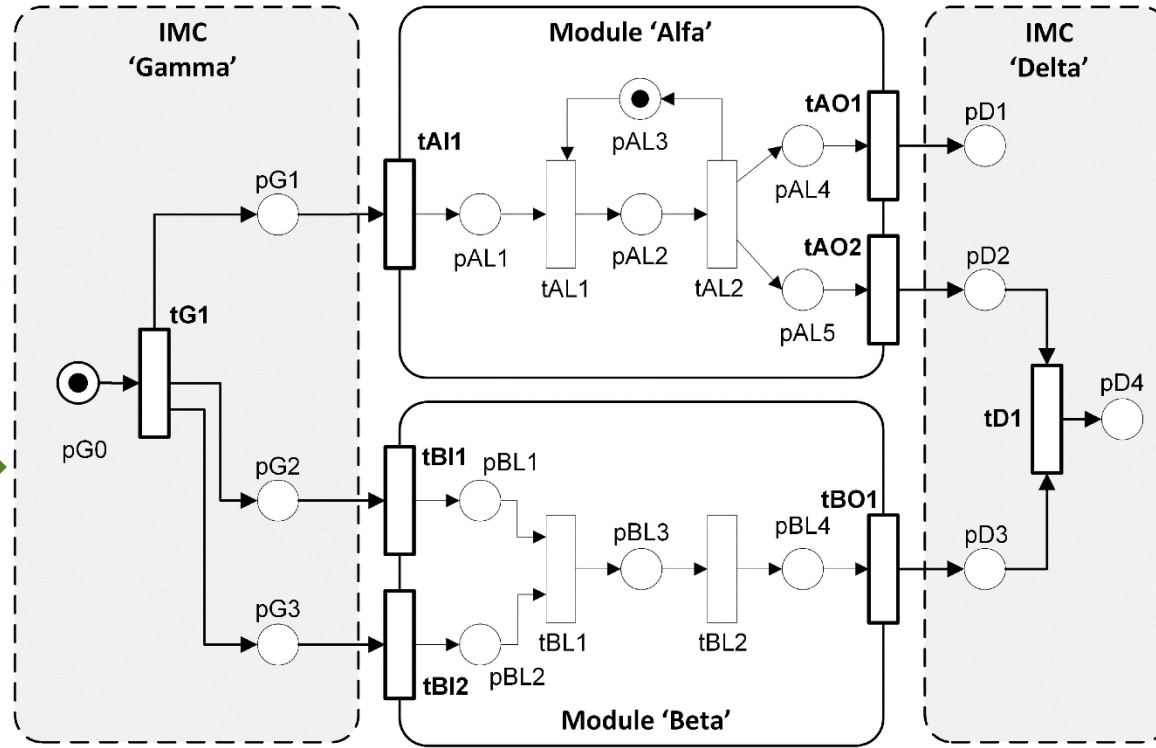

Prerequisite:
First-Rate System Architecture

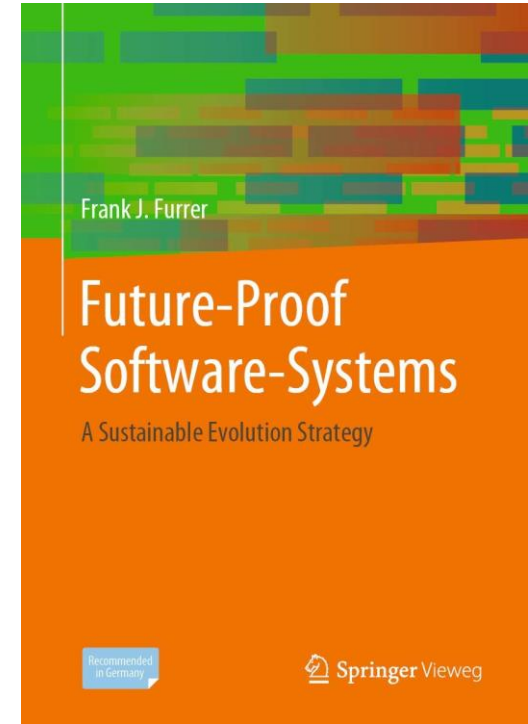

Distributed Development & Deployment

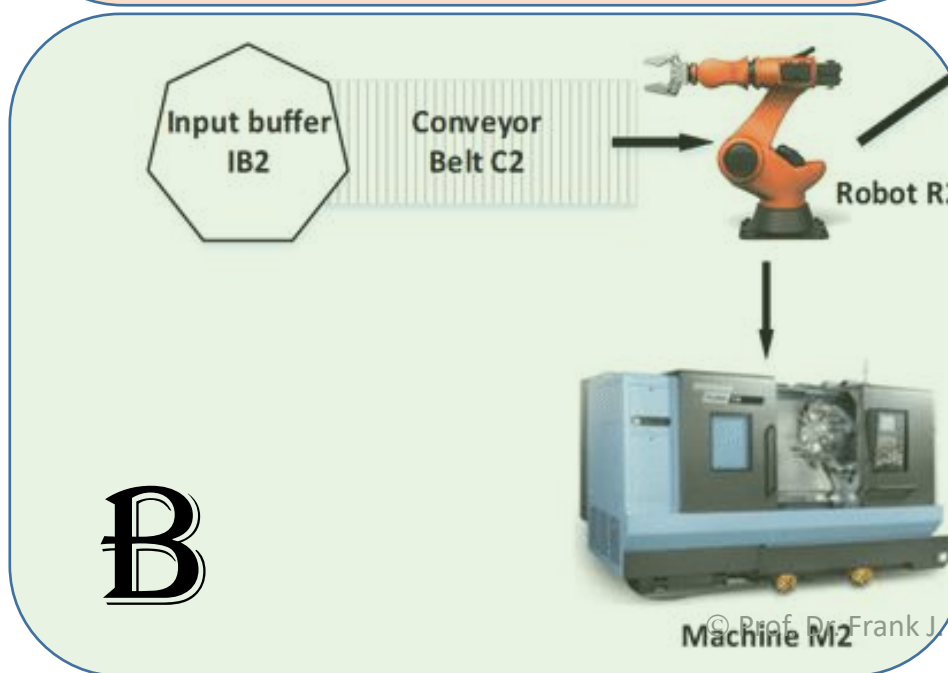
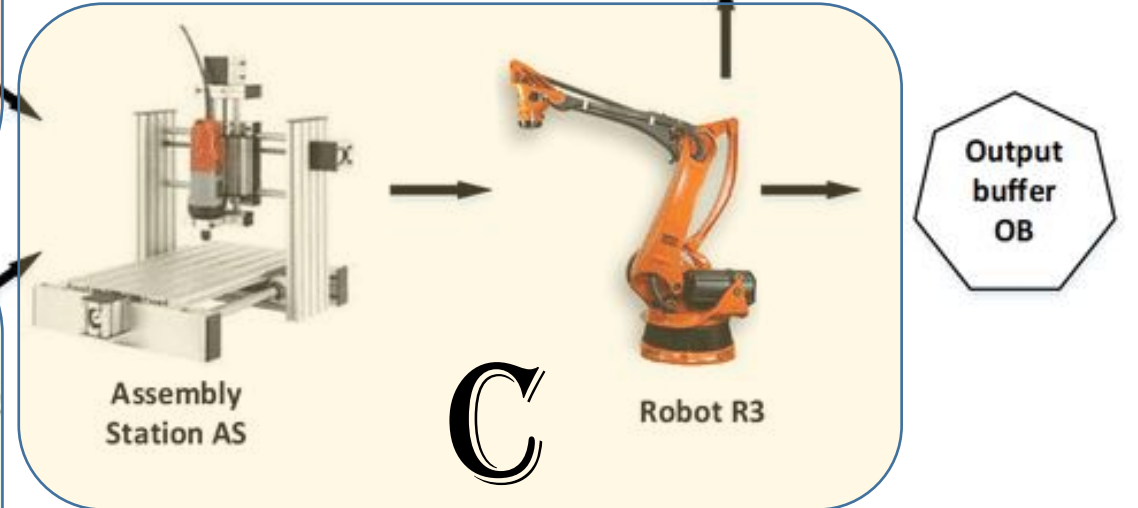
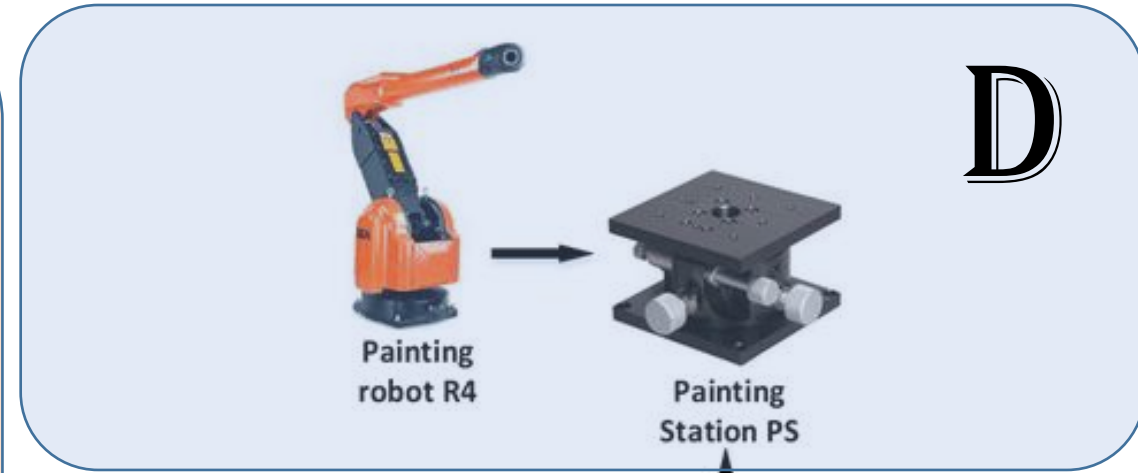
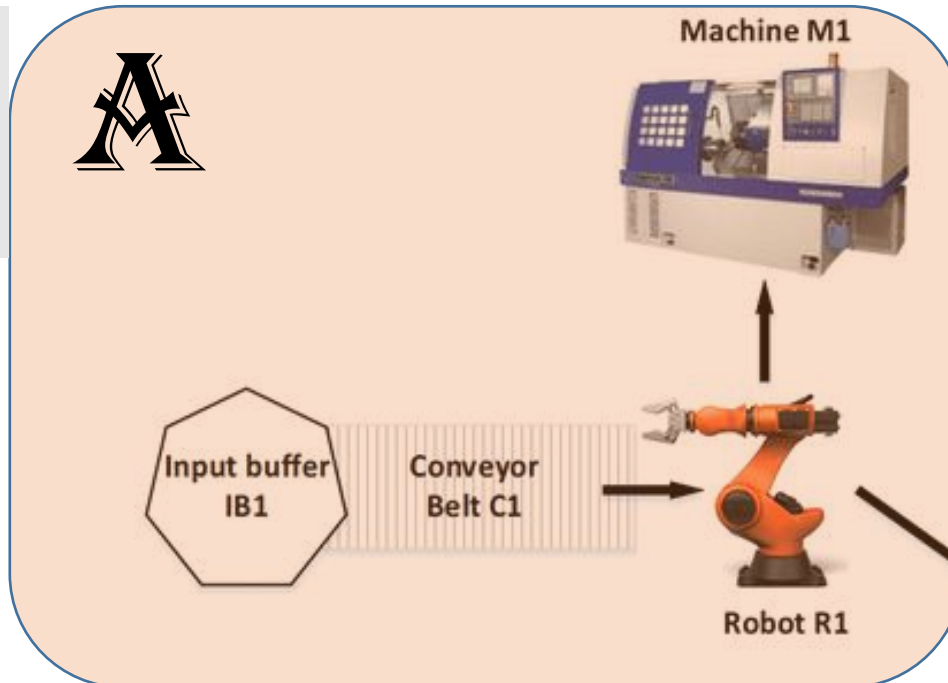

Distributed Development & Deployment

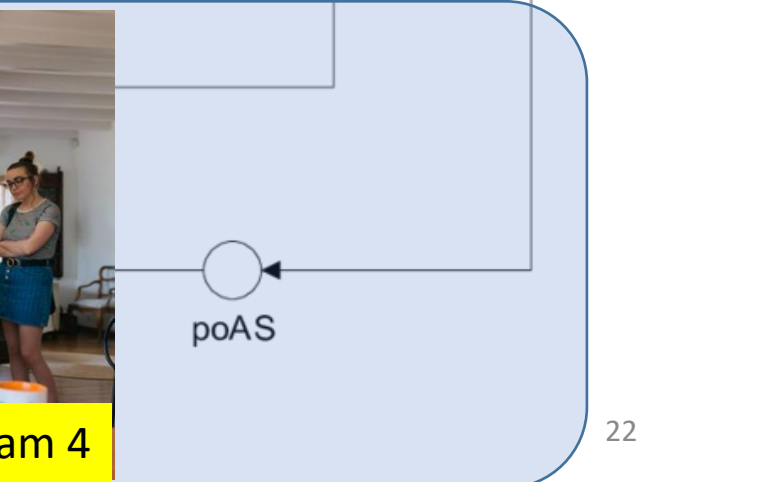
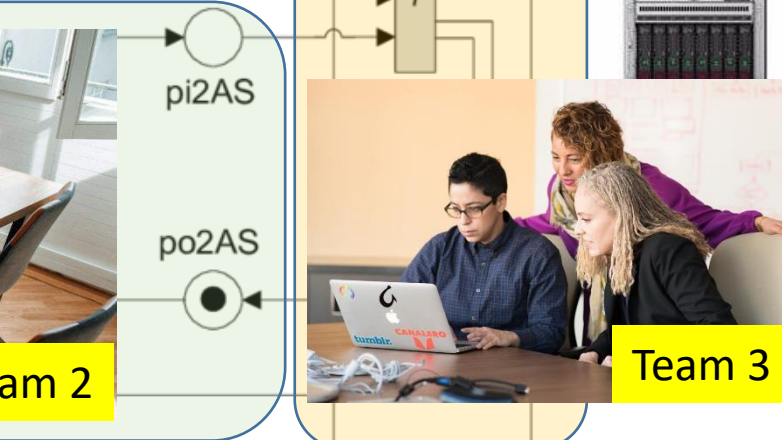
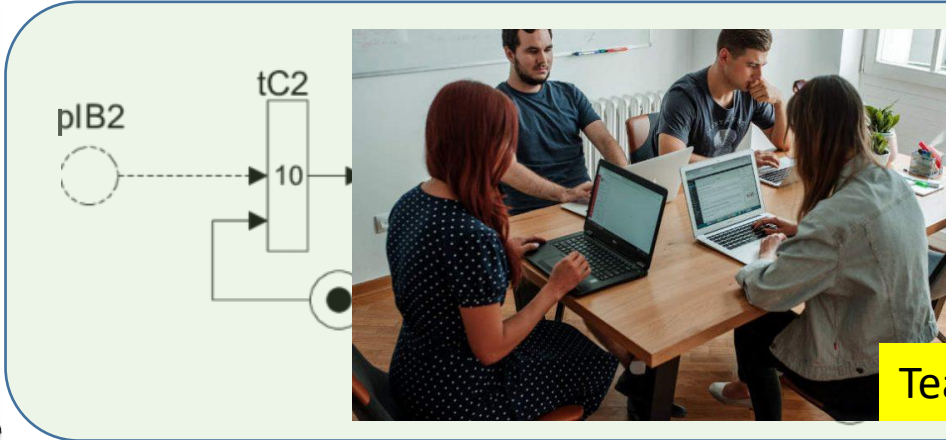
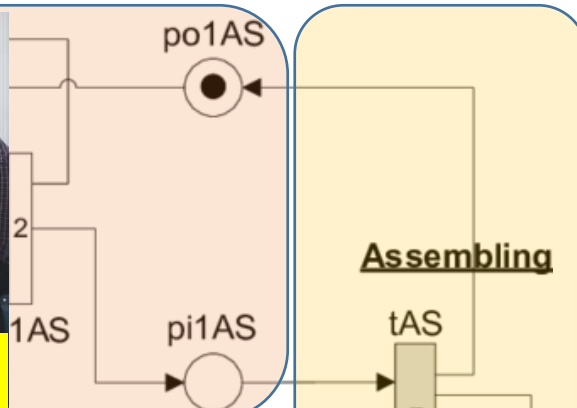
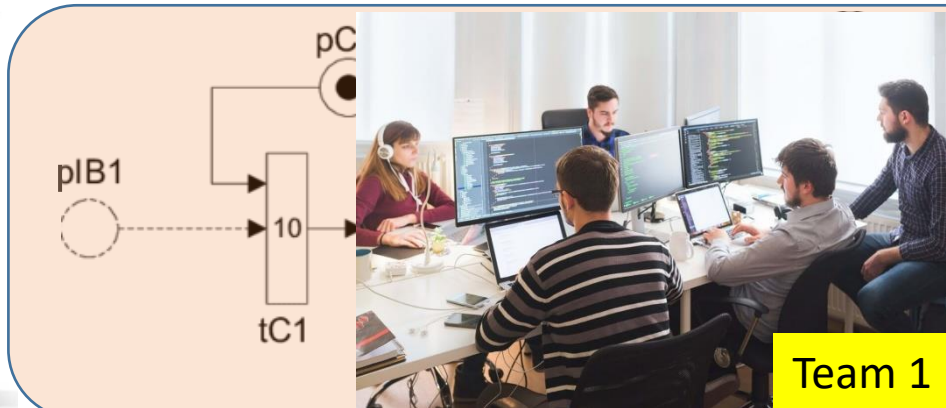

Modeling System-of-Systems [SoS, CPSoS]

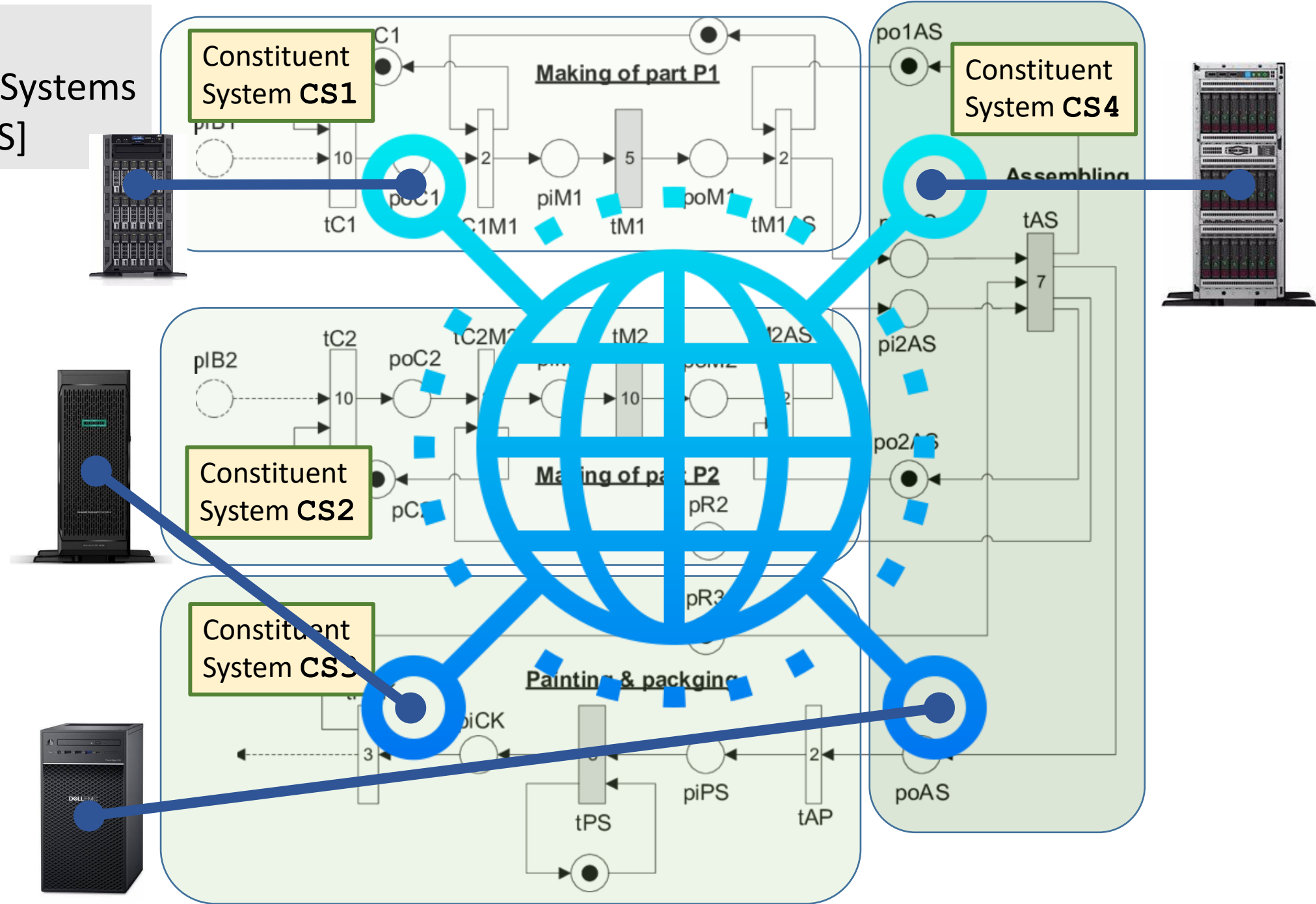

Modular Petri Net Simulator GPenSIM

```
% Main Simulation File (MSF) for
% the simple Petri Net

png = petrinetgraph('simple_def');
dyn.m0 = {'p1', 1, 'p2', 1};

dyn.ft = {'t1', 3};
pni = initialdynamics(png, dyn);
sim = gpensim(pni);

plotp(sim, {'p1', 'p2', 'p3'});
```

Modeling Discrete-Event Systems with GPenSIM describes the design and applications of the **General Purpose Petri Net Simulator (GPenSIM)**, a software tool for modeling, simulation, and performance analysis of discrete-event systems

The brief explains the principles of modeling discrete-event systems, as well as the design and applications of GPenSIM. The brief uses GPenSIM to enable the efficient **modeling of complex and large-scale discrete-event systems**. GPenSIM, based on MATLAB, is designed to allow easy integration of Petri net models with a vast number of toolboxes available in MATLAB.

<https://ch.mathworks.com/academia/books/modeling-discrete-event-systems-with-gpensim-davidrajuh.html>

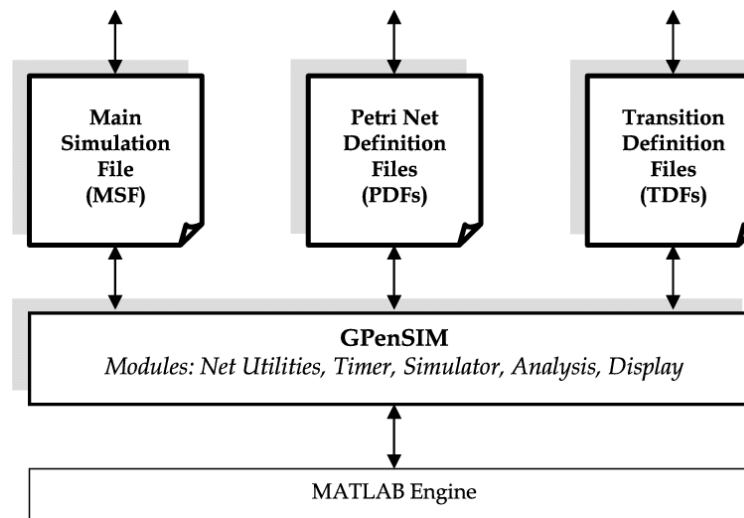
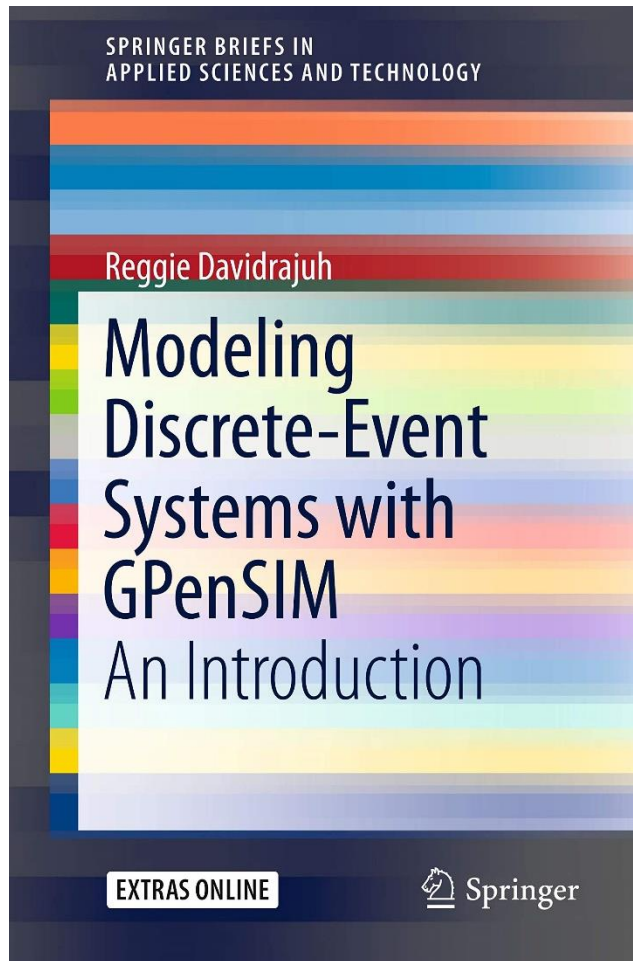

Legacy Petri Net Models \Rightarrow **Modular** Petri Net Models

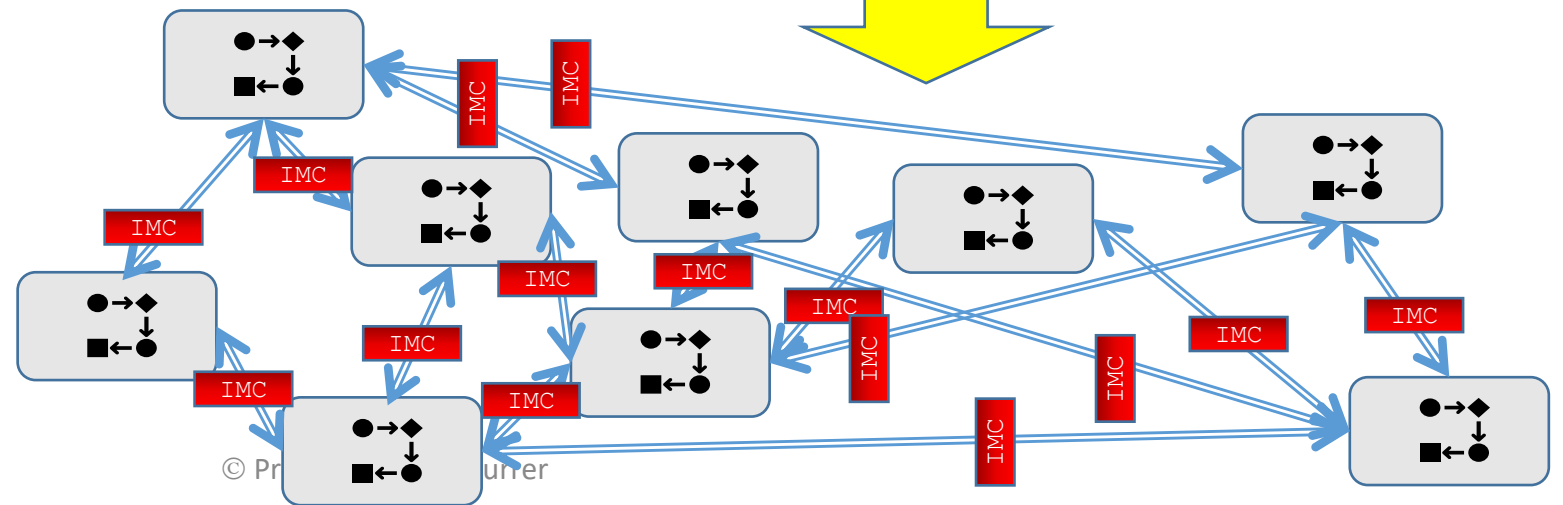
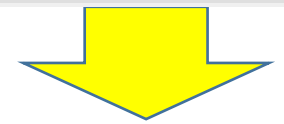
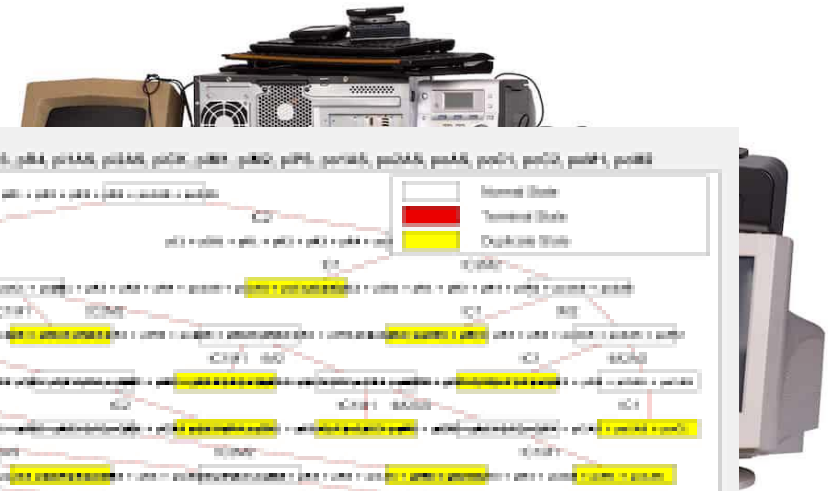

REGGIE DAVIDRAJUH:

Extracting Petri Modules From Large and Legacy Petri Net Models

Digital Object Identifier
10.1109/ACCESS.2020.3020213
2020

<https://uis.brage.unit.no/uis-xmlui/bitstream/handle/11250/3049494/09179742.pdf?sequence=1>

Conclusions



- (1) **Modular Petri Nets & Petri Modules** are a promising **modeling mechanism** for large, real-time cyber-physical systems
- (2) Due to the powerful partitioning the **Modular Petri Nets & Petri Modules** have a low **cognitive complexity** (= good understandability), even when the technical complexity is high
- (3) The **graphical representation** is intuitive and comprehensive. Due to the clear composition model, large systems can be represented well

Open Research Questions:

Inclusion of structural, information, and quality properties modeling

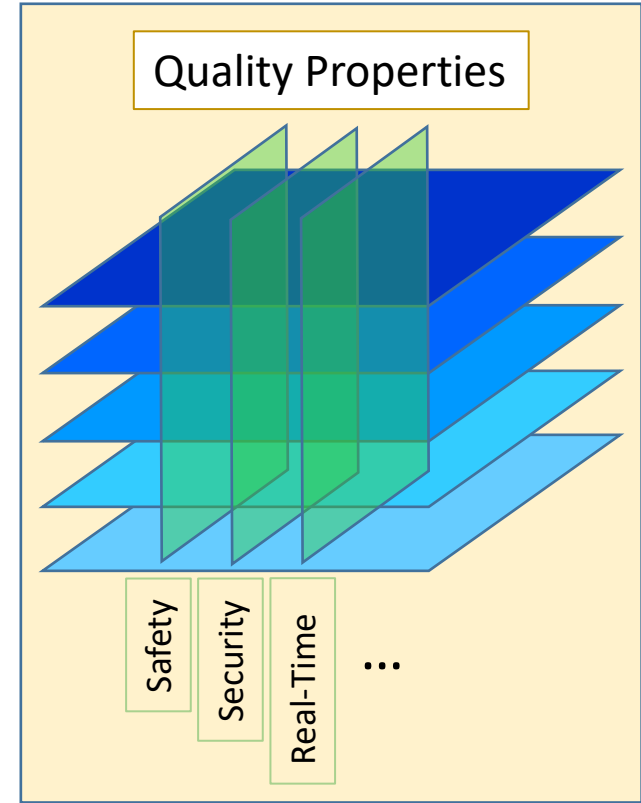
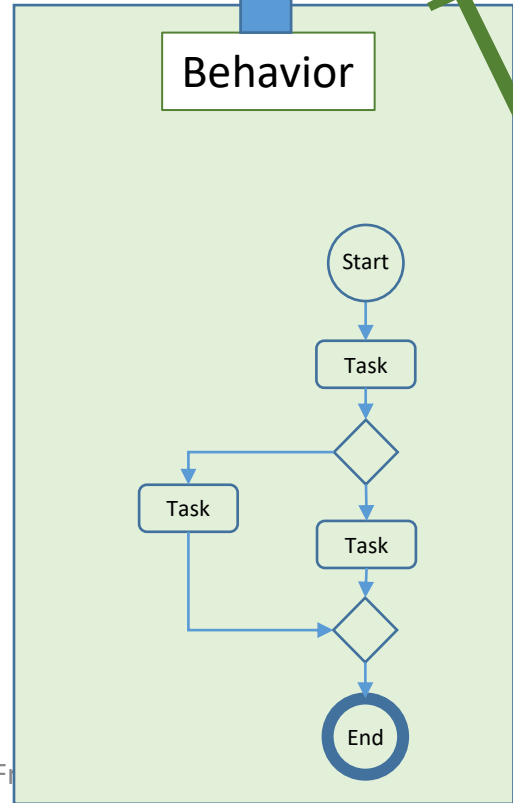
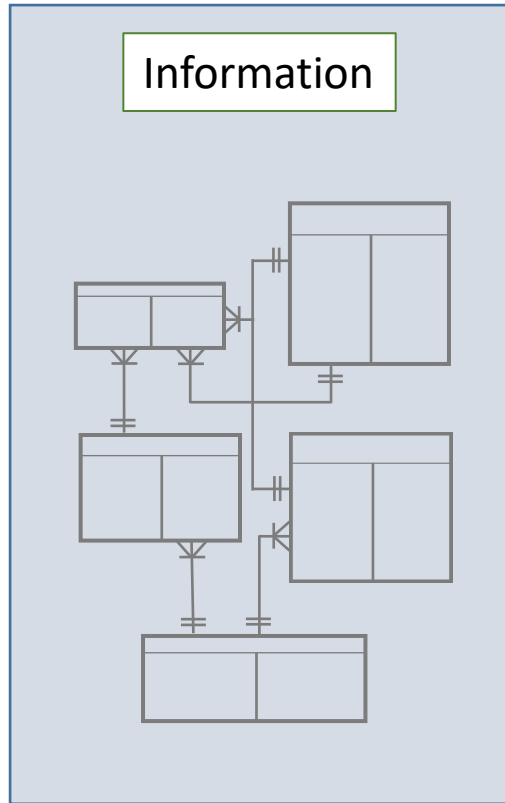
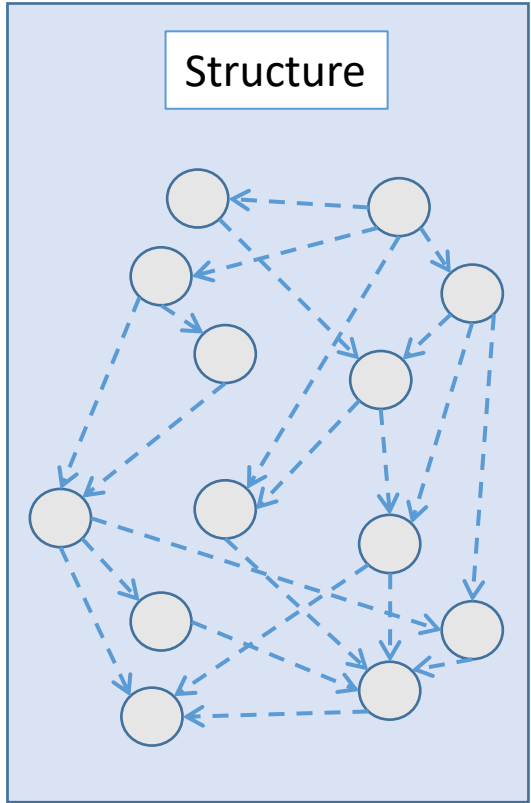
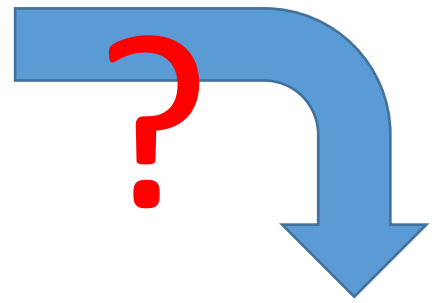
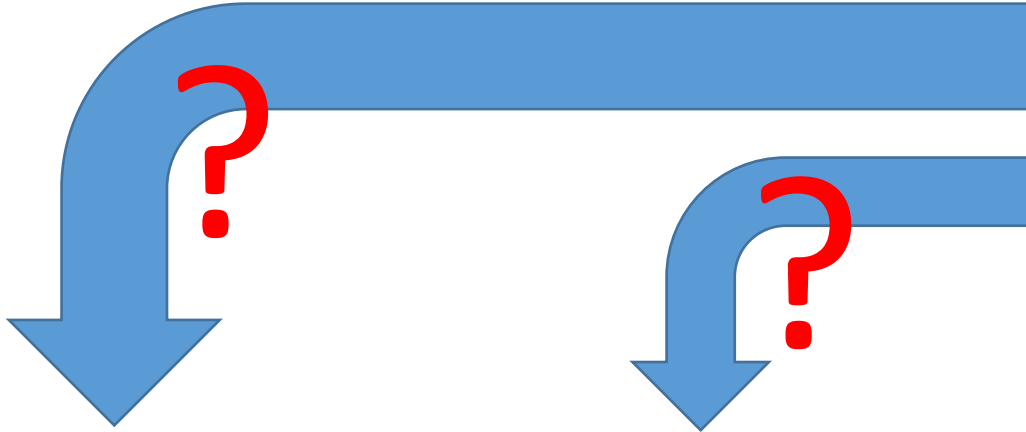
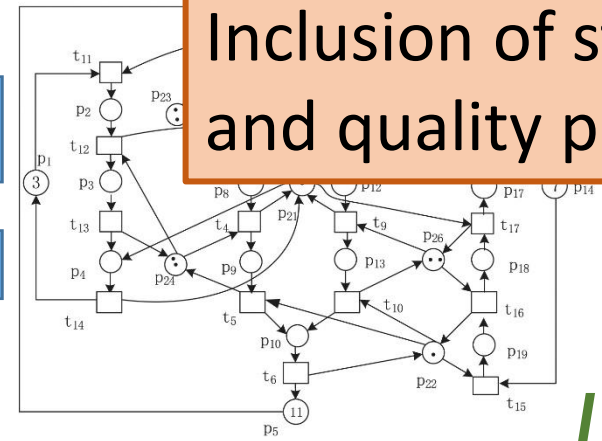



Wolfgang Reisig
Grzegorz Rozenberg *Eds.*

Carl Adam Petri: Ideas, Personality, Impact

 Springer

Wolfgang Reisig, Grzegorz Rozenberg (Editors):

Carl Adam Petri - Ideas, Personality, Impact

Springer Verlag, 2019
ISBN 978-3-319-96153-8

Reggie Davidrajuh:

Electrical Engineering and Computer Science University of Stavanger, Stavanger, Norway



(Suzhou, China; June 2006)

<http://www.davidrajuh.net/reggie/>